

MITSUBISHI

三菱工業用ミシン部品カタログ

Industrial Sewing Machine Parts Catalog

Model PLK-E5050
PLK-E10050

目次	CONTENTS	Page
[A] 全 体 構 成	Construction	1
[B] 本 体 関 係 (I)	Arm bed & It's accessories (I)	2
[C] 本 体 関 係 (II)	Arm bed & It's accessories (II)	4
[D] 縫 い 機 構 (I)	Sewing machanism (I)	6
[E] 縫 い 機 構 (II)	Sewing machanism (II)	8
[F] 中 押 え 機 構	Presser bar lifting mechanism	10
[G] 糸 切 り 機 構	Thread trimming mechanism	12
[H] 糸 緩 め 機 構	Tension release mechanism	14
[J] X-Yテ-ブル機構(I)	X-Y Table mechanism (I)	16
[K] X-Yテ-ブル機構(II)	X-Y Table mechanism (II)	18
[L] X-Yテ-ブル機構(III)	X-Y Table mechanism (III)	20
[M] 外 押 え 機 構	Work holder mechanism	22
[N] ワ イ パ - 機 構	Wiper mechanism	24
[P] 給 油 機 構	Oil lubrication mechanism	26
[Q] 配 線 ・ 配 管 関 係	Cable component & Pneumatic control unit	28
[R] テ - ブ ル 関 係	Table & Stand	30
[S] 付 属 品	Accessories	32
[T] オ プ シ ョ ン パ - ツ	Option parts	34
索 引	Index	36

ミシン用部品コードの採番基準

MITSUBISHI SPARE PARTS No. Designation system

1. 部品コードについて CONCERNING PARTS CODE.

部品を注文される場合は、部品コードをお知らせください。

Please inform the part number, when these parts are ordered.

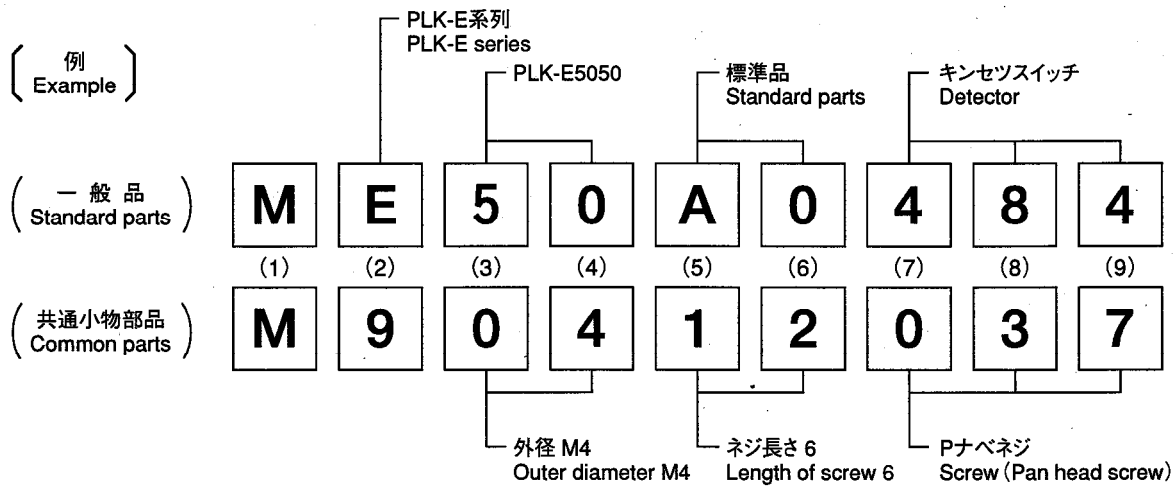
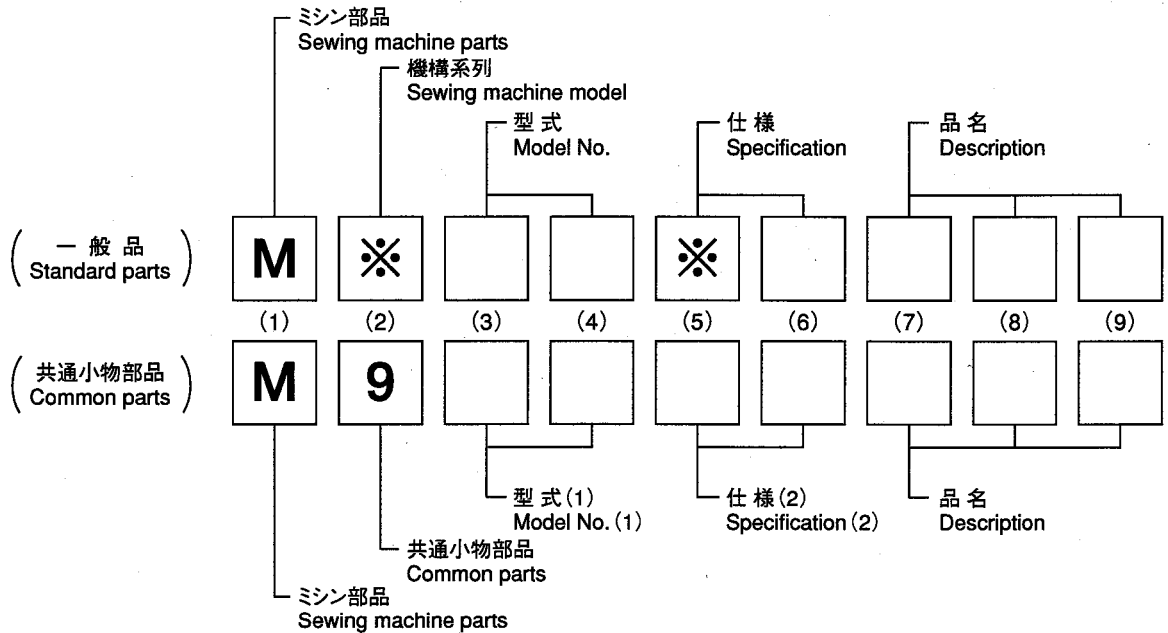

2. 変更マークについて CONCERNING MODIFICATION MARK.

変更マーク欄に*記号のある部品は、形状、寸法などの変更履歴がありますので、ご注文の際にはご使用の製品の製造番号と合わせてご覧ください。

The parts marked with * in the modification column has been changed the shape or size etc. So when these modified parts are ordered please inform the serial number of the sewing machine.

注：一般品についての機種型名は、その部品が最初に使用された機種型名を示します。従って長期にわたる場合は、機種の改廃が行われるため、当初の機種以外の機種で使用されている場合があります。

Sewing machine Models, of Standard Parts are indicated model of these parts are registered firstly. Parts are used for not only the indicated model, but also another models, in reason of New development, improvement after.

Ⓐ 全体構成
CONSTRUCTION

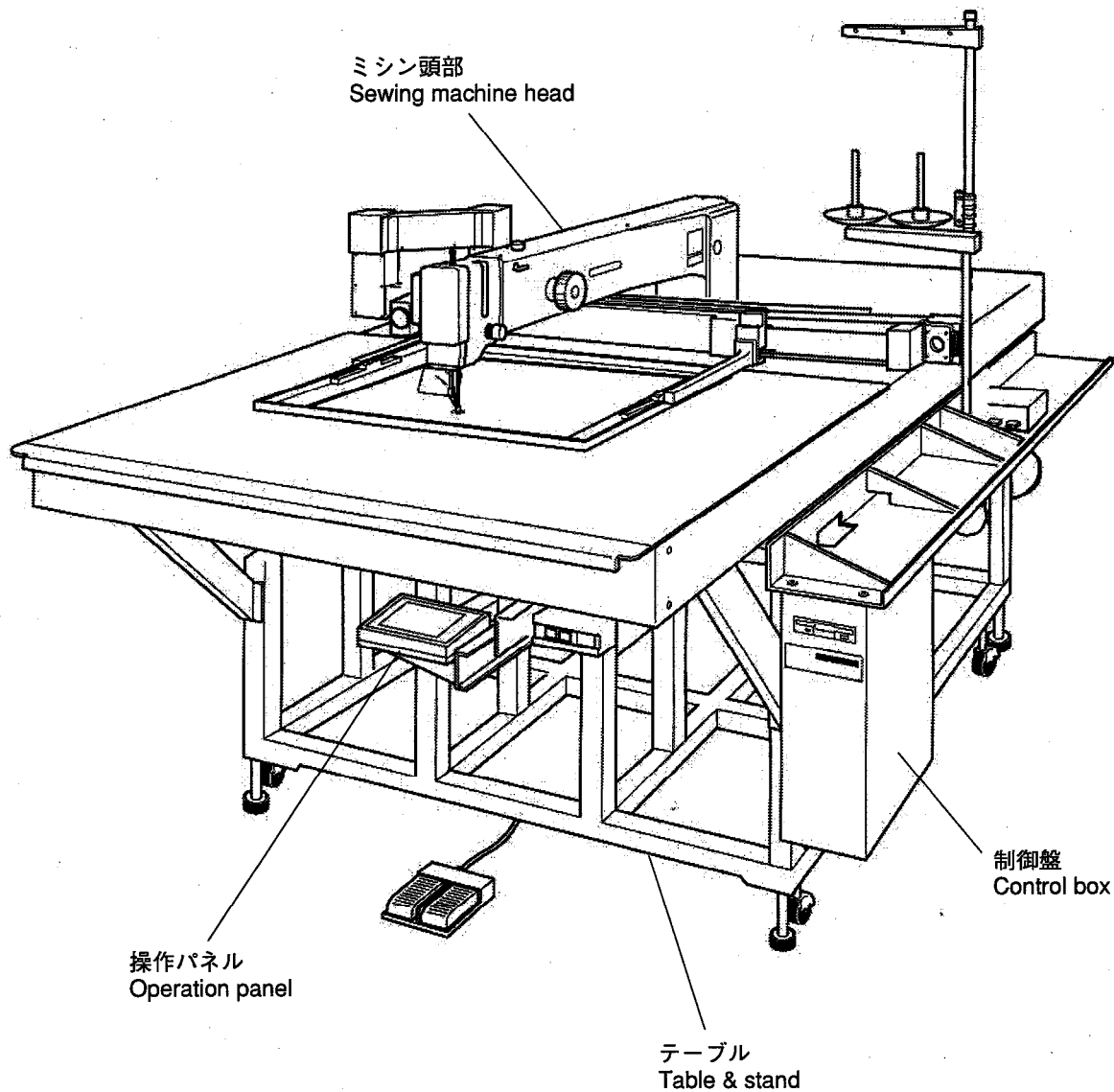

注1:モータ部分は三菱リミサーボX部品カタログを参照ください。

注2:Fig.No.の採番していない部品は単体で支給することはできません。Setにて支給いたします。

Remarks 1: Concerning about the motor parts please refer to the parts catalog of MITSUBISHI LIMISERBO X.

Remarks 2: The parts which Fig.No. are not marked are not available individually. It can be supplied with the whole component.

㊦ 本体関係 (I)
ARM BED & IT'S ACCESSORIES (I)

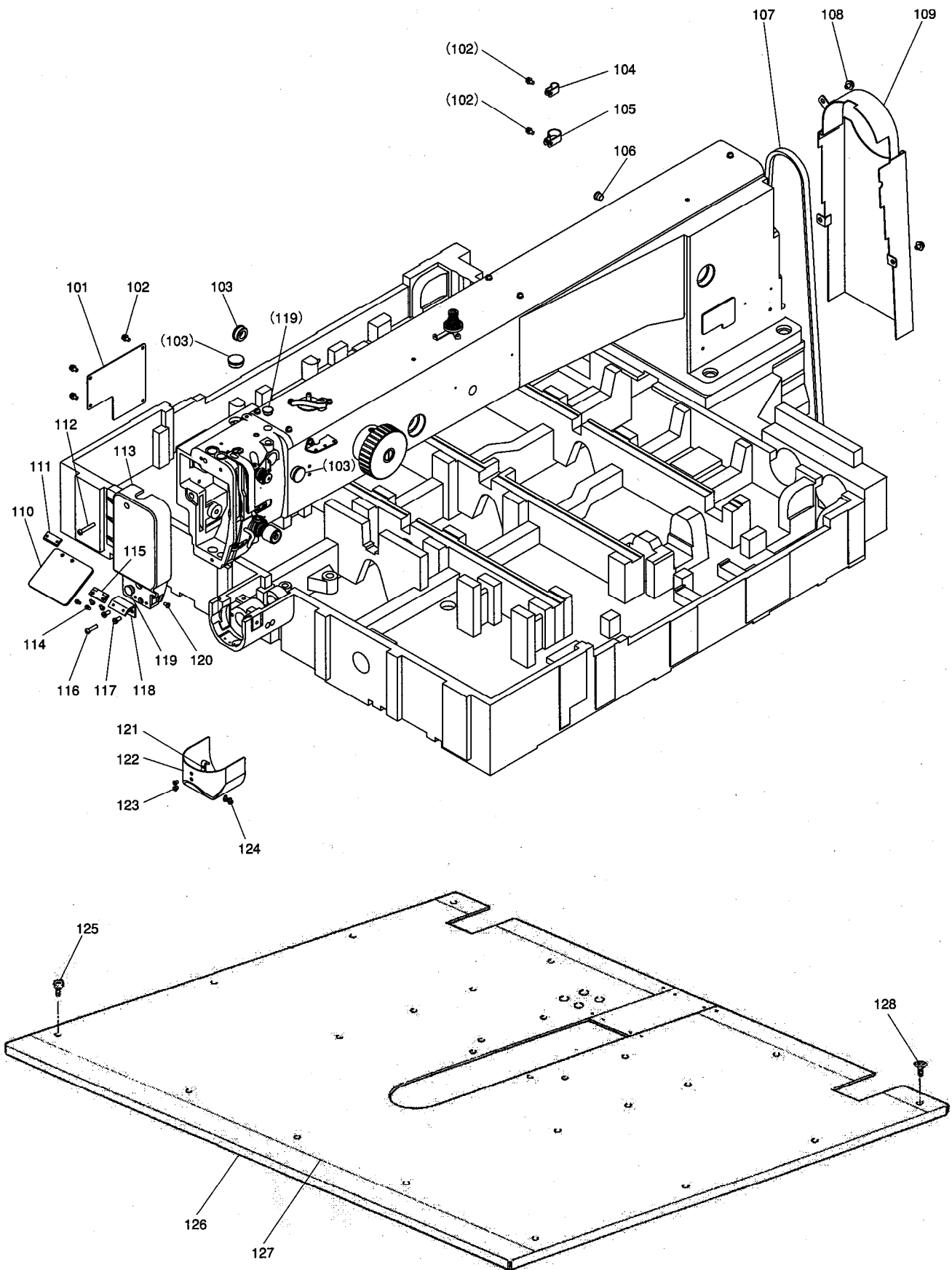

[B] 本体関係 (I)
ARM BED & IT'S ACCESSORIES (I)

Fig no.	変更 Mod.	部品コード Parts no.	品名	Description	数量	
					5050	10050
B 101	ME10A0742		フタ	Cover	1	1
B 102	M91054004		SW-PW プライナネジ M4X8	Screw M4X8	12	12
B 103	M91910080		ゴムセン φ19	Rubber plug φ19	3	3
B 104	MN60A0620		ナイロンクリップ AB-5N	Nylon clip AB-5N	7	7
B 105	MB60A1620		ナイロンクリップ AB-8N	Nylon clip AB-8N	1	1
B 106	M90883080		ゴムセン φ8.8	Rubber plug φ8.8	1	1
B 107	MB62A0777		Vベルト M46	V belt M46	1	1
B 108	M91300004		SW-MW プライナネジ M5X8	Screw M5X8	3	3
B 109	MB35E0776		ベルトカバー	Belt cover	1	1
B 110	MS01A0160		アイガード	Eye guard	1	1
B 111	MS01A0477		ストッパ	Adapter	1	1
B 112	M90447037		プライナネジ M4X25	Screw M4X25	1	1
B 113	ME10E1830		メンタ	Face cover	1	1
B 114	M90806002		ヒラネジ 1/8(44)X6	Screw 1/8(44)X6	4	4
B 115	MS01A1739		ヒンジ	Hinge	1	1
B 116	M91079004		プライナネジ M4X16	Screw M4X16	1	1
B 117	M91110002		ヒラネジ 11/64(40)X8	Screw 11/64(40)X8	2	2
B 118	MB60A0601		アイガードトリツケイタ	Eye guard bracket	1	1
B 119	M91182080		ゴムセン φ11.8	Rubber plug φ11.8	2	2
B 120	M90909003		マルヒラネジ 9/64(40)X6	Screw 9/64(40)X6	1	1
B 121	MS01A0361		カケガネ	Latch	1	1
B 122	MB60E6339		シリンダーカバー	Cylinder cover	1	1
B 123	M90906003		マルヒラネジ 9/64(40)X3.2	Screw 9/64(40)X3.2	2	2
B 124	M90859004		SW-PW プライナネジ M3X6	Screw M3X6	2	2
B 125	M90992002		ヒラネジ M4X8	Screw M4X8	25	54
B 126	MB50E0470		スベリイタ	Slide plate	1	*
B 126	MB15E0470		スベリイタ	Slide plate	*	1
B 127	MB50A0797		ホコフィルム	Film sheet	1	*
B 127	MB15A0797		ホコフィルム	Film sheet	*	1
B 128	M91064004		サラネジ M4X6	Screw M4X6	36	36

㊦ 本体関係(Ⅱ)
ARM BED & IT'S ACCESSORIES(Ⅱ)

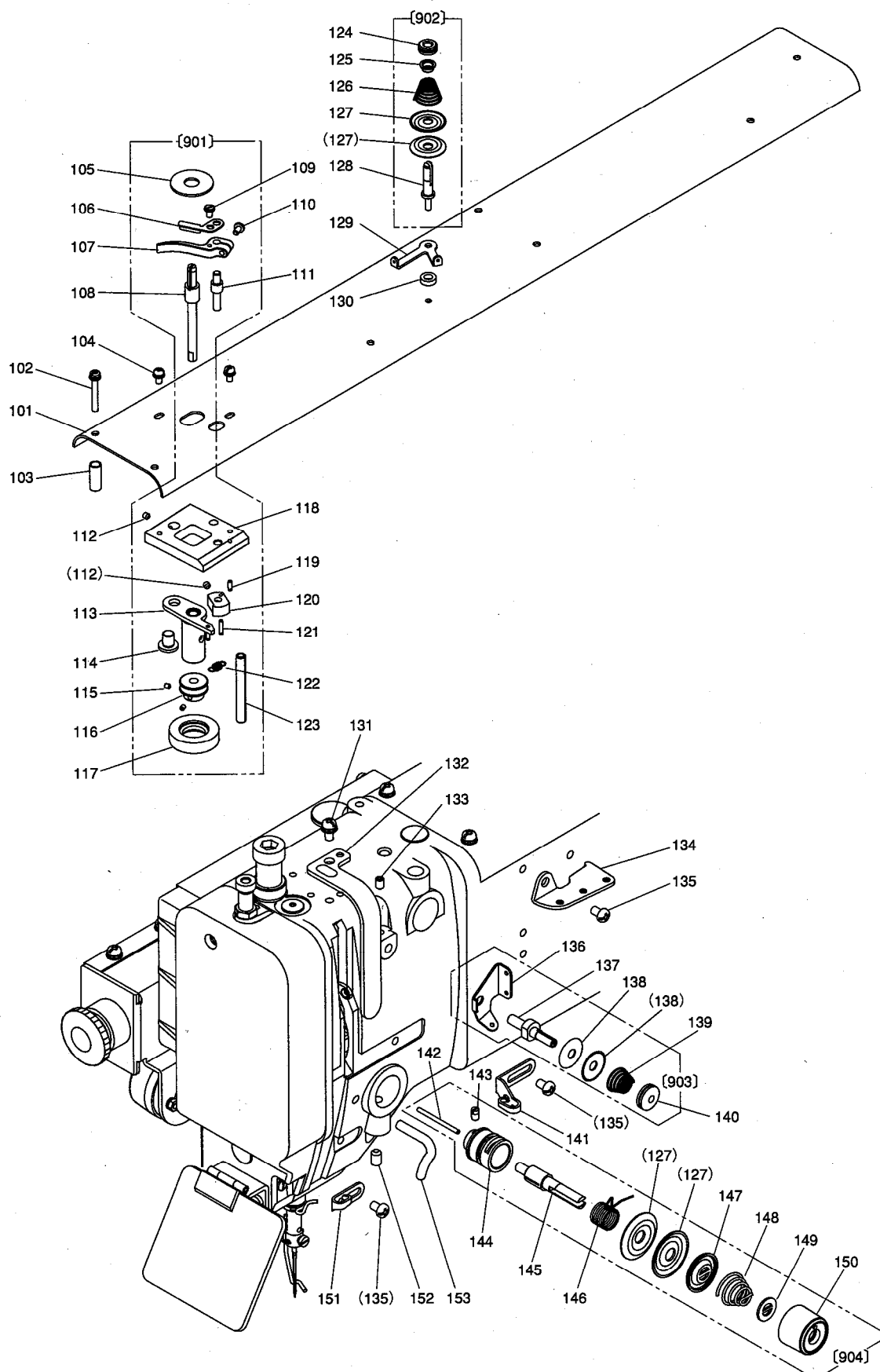

[C]本体関係(Ⅱ)

ARM BED & IT'S ACCESSORIES(Ⅱ)

Fig no.	変更 Mod.	部品コード Parts no.	品名	Description	数量	
					5050	10050
C 101		MB35A0600	トップカバー	Top cover	1	1
C 102		M91276004	SW-PWプライナベネジ M4X30	Screw M4X30	5	5
C 103		MB62A0352	スペーサ 1382312-60200	Spacer	5	5
C 104		M91013004	SW-MWプライナベネジ M4X10	Screw M4X10	2	2
C 105		MA20A0476	スペーサ	Spacer	1	1
C 106		ME25A0551	チョウセツイタ	Adjuster plate	1	1
C 107		ME25A0950	レバー	Lever	1	1
C 108		MA04A1530	ダンツキジク D	Driven shaft	1	1
C 109		M90920002	ヒラネジ 9/64(40)X6.5	Screw 9/64(40)X6.5	1	1
C 110		M90939002	ヒラネジ 9/64(40)X11	Screw 9/64(40)X11	1	1
C 111		ME25A0530	ダンツキジク	Shaft	1	1
C 112		M91055020	ロックアナツキメネジ M4X4	Screw M4X4	2	2
C 113		MB60E2750	レバークミタテ	Lever	1	1
C 114		M99006063	ピン	Pin	1	1
C 115		M91057020	ロックアナツキメネジ M3X4	Screw M3X4	2	2
C 116		MA20A0194	イマキグルマ	Wheel	1	1
C 117		MS03A0417	ゴムワ	Tire	1	1
C 118		MB60A1601	トリツケイタ	Bracket	1	1
C 119		M91004067	ミゾツキピン BXガタ φ2.5X8	Pin φ2.5X8	1	1
C 120		MS14A0350	カム	Cam	1	1
C 121		M91005067	ミゾツキピン BXガタ φ2.5X12	Pin φ2.5X12	2	2
C 122		MS14A0572	ツルマキバネ	Spring	1	1
C 123		M90601064	スプリングピン φ6X56	Pin φ6X56	1	1
C 124		M91602046	ツマミナット	Thumb nut	1	1
C 125		MM11A0702	バネアンナイ	Spring guide	1	1
C 126		MM11A0245	エンスイバネ	Thread tension spring	1	1
C 127		MF10A0555	チョウシガラ	Thread tension discs	4	4
C 128		MS14A0553	チョウシボウ	Thread tension stud	1	1
C 129		MS14A1180	イトアンナイ	Thread guide	1	1
C 130		MG75A1476	スペーサ	Spacer	1	1
C 131		M91054004	SW-PWプライナベネジ M4X8	Screw M4X8	1	1
C 132		MA20A0584	テンピンカバー	Thread take-up lever guard	1	1
C 133		M91053020	ロックアナツキメネジ M4X6	Screw M4X6	1	1
C 134		MF36A1180	イトアンナイ	Thread guide	1	1
C 135		M91011004	プライナベネジ M4X6	Screw M4X6	3	3
C 136		MF00A0181	イトアンナイ	Thread guide	1	1
C 137		MF90A0553	チョウシボウ	Thread tension stud	1	1
C 138		MF10A1555	チョウシガラ	Thread tension discs	2	2
C 139		MF36A0245	エンスイバネ	Thread tension spring	1	1
C 140		M91101046	ツマミナット	Thumb nut	1	1
C 141		MG43A0181	イトアンナイ	Thread guide	1	1
C 142		M90204060	ピン	Pin	1	1
C 143		M90901002	ヒラネジ 9/64(40)X4	Screw 9/64(40)X4	1	1
C 144		MF10A0709	ブッシュ	Regulator casing	1	1
C 145		MF10A0553	チョウシボウ	Thread tension stud	1	1
C 146		MF10A0187	イトリバネ	Thread take-up spring	1	1
C 147		MM11A0556	チョウシガラオサエ	Disc retaining plate	1	1
C 148		MN52A1245	エンスイバネ	Thread tension spring	1	1
C 149		MT60A0802	マワリドメ	Thumb nut revolution stopper	1	1
C 150		M91610046	ツマミナット	Thumb nut	1	1
C 151		MF10A0181	イトアンナイ	Thread guide	1	1
C 152		M95004020	ロックアナツキメネジ M5X8	Screw M5X8	1	1
C 153		MF70A1180	イトアンナイ	Thread guide	1	1
C 901		ME25E0190	イマキソウチクミタテ	Bobbin winder	1	1
C 902		MS14E0180	チョウセツキミタテ	Thread tension Regulator assy	1	1
C 903		MF00E0550	チョウセツキミタテ	Thread tension Regulator assy	1	1
C 904		MA16E0210	チョウセツキミタテ	Thread tension Regulator assy	1	1

D 縫い機構 (I)
 SEWING ACCESSORIES (I)

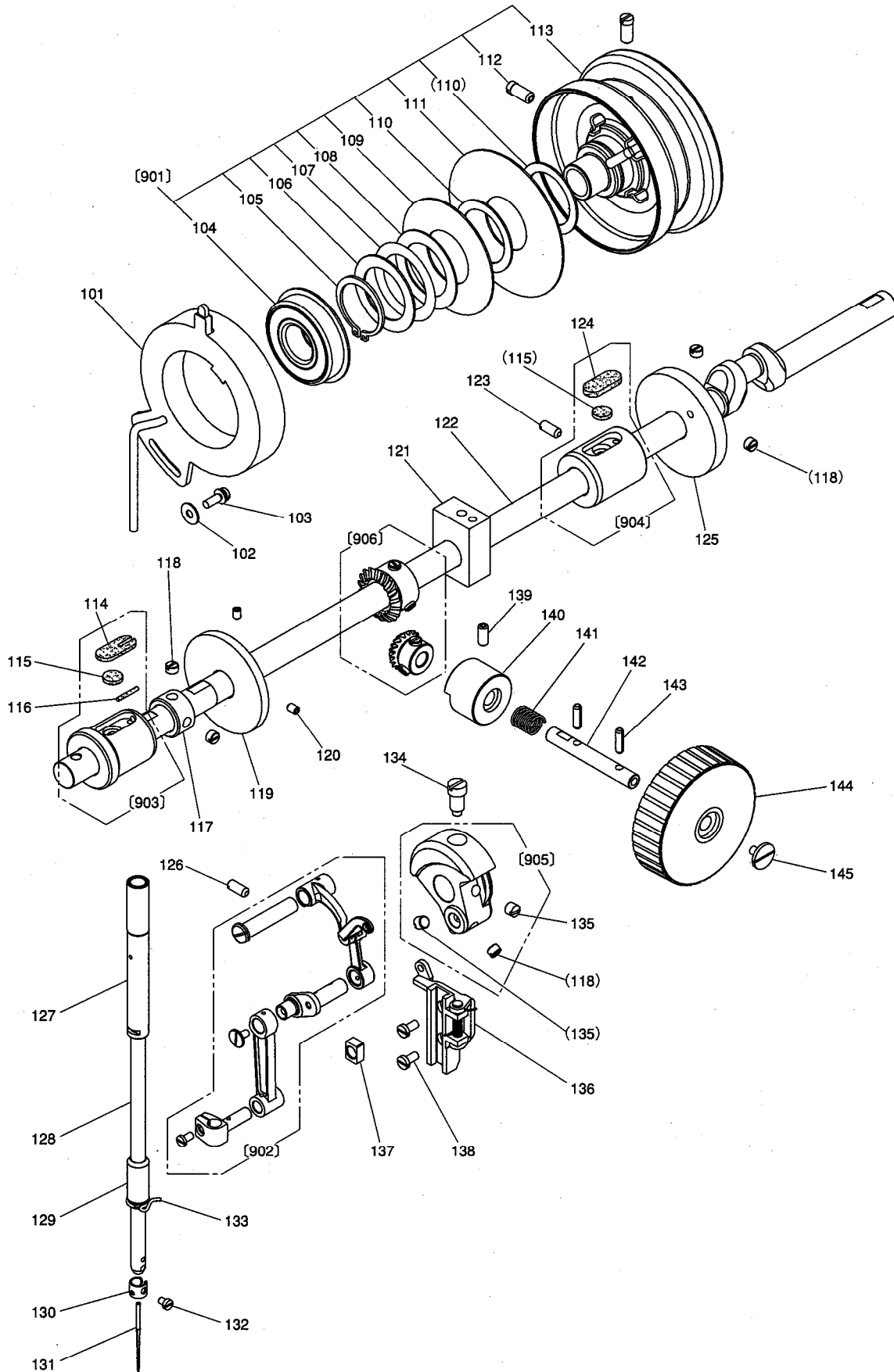

[D]縫い機構(I)
SEWING MECHANISM(I)

Fig no.	変更 Mod.	部品コード Parts no.	品名	Description	数量	
					Amt. 5050	Req. 10050
D 101		MB60A2406	ウワジクケンシュツキ	Detector	1	1
D 102		M90421050	ザガネ 4	Washer 4	1	1
D 103		M91059004	SW-PWプラマイナネジ M4X12	Screw M4X12	1	1
D 104		MN10A1456	ボールベアリング	Ball bearing	1	1
D 105		M90330065	Cガタメワ 30	C-type retaining ring 30	1	1
D 106		M93001050	ザガネ	Washer	1	1
D 107		MF01A0259	ナミザガネ	Wave washer	1	1
D 108		MF01A1476	スペーサー B	Spacer B	1	1
D 109		MN72A1694	ハンジャパン F20 (ウワイチ)	Command disk F20 (up)	1	1
D 110		MF01A0476	スペーサー A	Spacer A	2	2
D 111		MB60A0694	ハンジャパン K10 (シタイチ)	Command disk K10 (down)	1	1
D 112		M91520002	ヒラネジ 15/64(28)X12	Screw 15/64(28)X12	2	2
D 113		MB60E0682	プーリ	Pulley	1	1
D 114		MG50A0740	フェルト	Felt	1	1
D 115		MS10A1740	フェルト	Felt	2	2
D 116		MV88A0740	フェルト	Felt	1	1
D 117		MF70A0352	カラー	Collar	1	1
D 118		M91602001	トメネジ 1/4(40)X4	Screw 1/4(40)X4	5	5
D 119		MS14A0682	イトマキプーリ	Pulley	1	1
D 120		M91053020	ロッカクアナツキトメネジ M4X6	Screw M4X6	2	2
D 121		MA35A0833	メタル	Bushing	1	1
D 122		MB35A0230	ウワジク	Drive shaft	1	1
D 123		M91223001	トメネジ M5X10	Screw M5X10	1	1
D 124		MF60A2740	フェルト	Felt	1	1
D 125		MS01A0350	イトキリカム	Thread trimmer cam	1	1
D 126		M91221001	トメネジ M5X12	Screw M5X12	1	1
D 127		MS01A0663	ハリホウメタル (ウエ)	Needle bar bushing (upper)	1	1
D 128		MS01A0660	ハリホウ	Needle bar	1	1
D 129		MG30A0664	ハリホウメタル (シタ)	Needle bar bushing (lower)	1	1
D 130		MF21D0181	イトアンナイ	Thread guide	1	1
D 131		MS02A0128	ミシンハリ DPX17#18	Needle DPX17#18	1	1
D 132		M90815002	ヒラネジ 1/8(44)X4.5	Screw 1/8(44)X4.5	1	1
D 133		MF01A0181	イトアンナイ	Thread guide	1	1
D 134		M91802006	ヒラネジホウサキ 9/32(28)	Set screw 9/32(28)	1	1
D 135		M91606001	トメネジ 1/4(40)X6	Screw 1/4(40)X6	2	2
D 136		MS03E0662	ハリカイトクミタテ	Guide assy	1	1
D 137		MF10A0325	カクコマ	Square block	1	1
D 138		M90990002	ヒラネジ M4X8	Screw M4X8	2	2
D 139		M95006020	ロッカクアナツキトメネジ M5X12	Screw M5X12	1	1
D 140		ME25A0833	メタル	Bushing	1	1
D 141		MA35A2572	ツルマキバネ	Spring	1	1
D 142		ME25A0454	ジク	Shaft	1	1
D 143		M90406064	スプリングピン φ4X14	Pin. φ4X14	2	2
D 144		ME25A0682	テマワシプーリ	Hand pully	1	1
D 145		M91119002	ヒラネジ	Screw M4X8	1	1
D 901		MB60E1682	プーリクミタテ	Pulley assy	1	1
D 902		MS01E0580	テンピンハリカクミタテ	Thread take-up lever assy	1	1
D 903		MS10A0232	ウワジクメタル(ヒタリ)クミ	Drive shaft bushing L assy	1	1
D 904		MB60E0234	ウワジクメタル(ナカ)クミ	Drive shaft bushing C assy	1	1
D 905		MS01A0383	クランククミ	Crank assy	1	1
D 906		ME25E0331	カサハグルマクミ	Bevel gear assy	1	1

縫い機構(Ⅱ)
SEWING MECHANISM(Ⅱ)

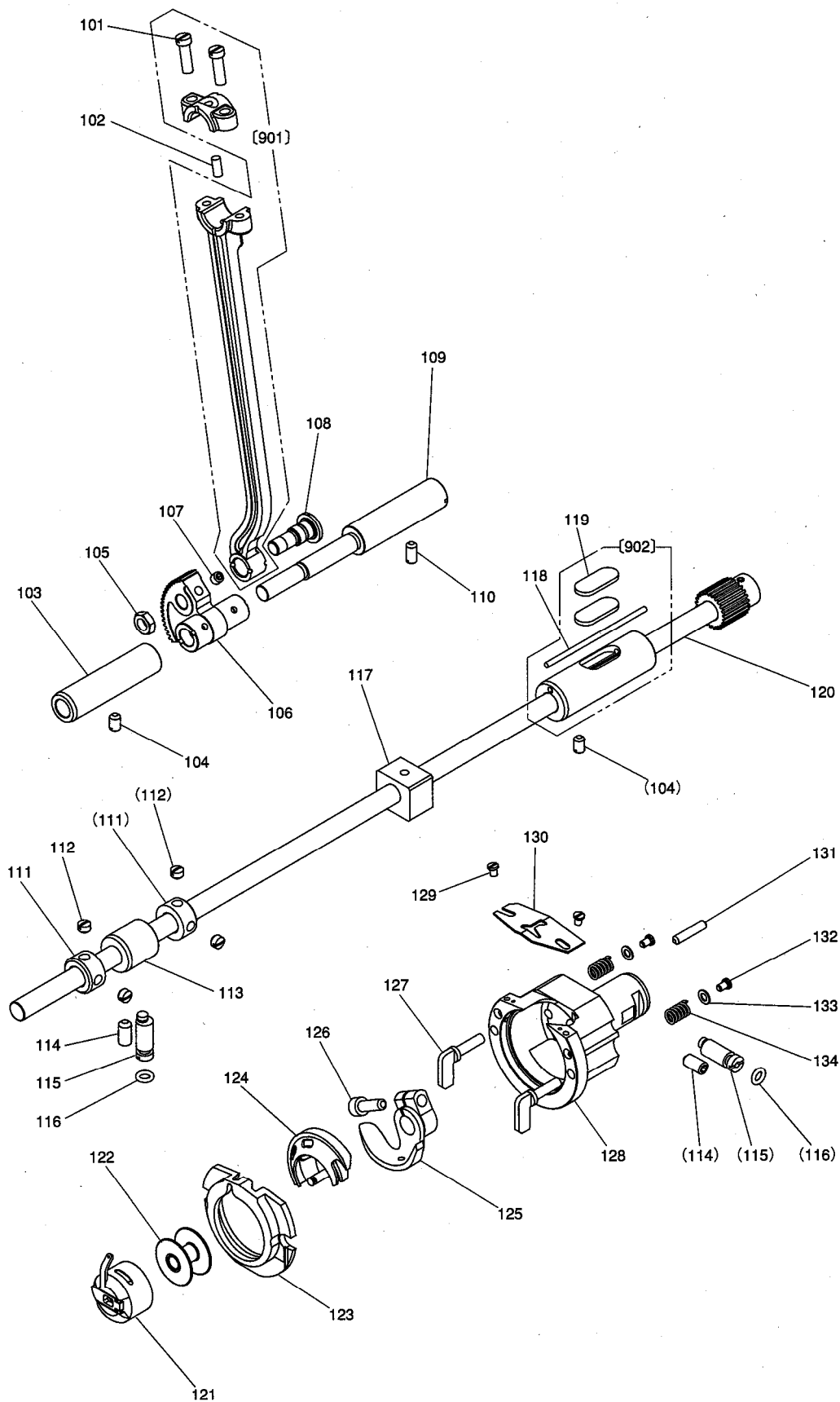

From the library of: Diamond Needle Corp

[E] 縫い機構(Ⅱ)
SEWING MECHANISM(Ⅱ)

Fig no.	変更 Mod.	部品コード Parts no.	品 名	Description	数量	
					5050	10050
E 101		M91203002	ヒラネジ 3/16(28)X15	Screw 3/16(28)X15	2	2
E 102		MB60A0740	フェルト	Felt	1	1
E 103		MS01A0833	メタル	Bushing	1	1
E 104		M91223001	トメネジ M5X10	Screw M5X10	2	2
E 105		M91802045	ナット 9/32(28)	Nut 9/32(28)	1	1
E 106		MS01A0508	セクタハグルマ	Sector gear	1	1
E 107		M95004021	ロッカクアナツキトメネジ M5X5	Screw M5X5	1	1
E 108		M98003015	ヒラネジダツキ 9/32(28)	Screw 9/32(28)	1	1
E 109		MS01A0891	ヨウドウジク	Rock shaft	1	1
E 110		M91221001	トメネジ M5X12	Screw M5X12	1	1
E 111		MM11A0352	カラー	Collar	2	2
E 112		M91503001	トメネジ 15/64(28)X4.5	Screw 15/64(28)X4.5	4	4
E 113		MB62A0453	シタジクメタル(ナカ)	Hook shaft bushing (C)	1	1
E 114		M91650020	ロッカクアナツキトメネジ M6X8	Screw M6X8	2	2
E 115		MS01A0761	ヘンシンジク	Eccentric shaft	2	2
E 116		M90500085	O リング	O-ring	2	2
E 117		MA35A1833	メタル	Bushing	1	1
E 118		ME10A0148	ヒモ	Oil braid	1	1
E 119		MA20A0740	フェルト	Felt	2	2
E 120		MA35E0450	シタジク クミ	Hook shaft assy	1	1
E 121		MS17A0125	ボビンケース SC-181	Bobbin case	1	1
E 122		MA10A0123	ボビン	Bobbin	1	1
E 123		MS08A0616	ナカガマオサエ	Hook retainer	1	1
E 124		MA10A0120	ナカガマ	Inner hook	1	1
E 125		MS01A0611	ドライバ	Hook driver	1	1
E 126		M95001021	ロッカクアナツキボルト M5X16	Bolt M5X16	1	1
E 127		MS09A0950	カマオサエツマミ	Hook clamp	2	2
E 128		MS01A0121	ソトガマ	Outer hook	1	1
E 129		M90853002	ヒラネジ 1/8(40)X4	Screw 1/8(40)X4	2	2
E 130		MS01A0329	カマイトアンナイ	Thread guide	1	1
E 131		M90001060	ヘイコウピン M6-4X18	Pin M6-4X18	1	1
E 132		M90802003	マルヒラネジ 1/8(44)X4.5	Screw 1/8(44)X4.5	2	2
E 133		M93006050	ザガネ	Washer	2	2
E 134		MS01A0572	ツルマキバネ	Spring	2	2
E 901		MB60E1956	レンセツカン クミ	Connecting rod assy	1	1
E 902		ME10E0452	シタジクメタル(ミキ)クミ	Hook shaft bushing (R) assy	1	1

中押え機構
PRESSER BAR LIFTING MECHANISM

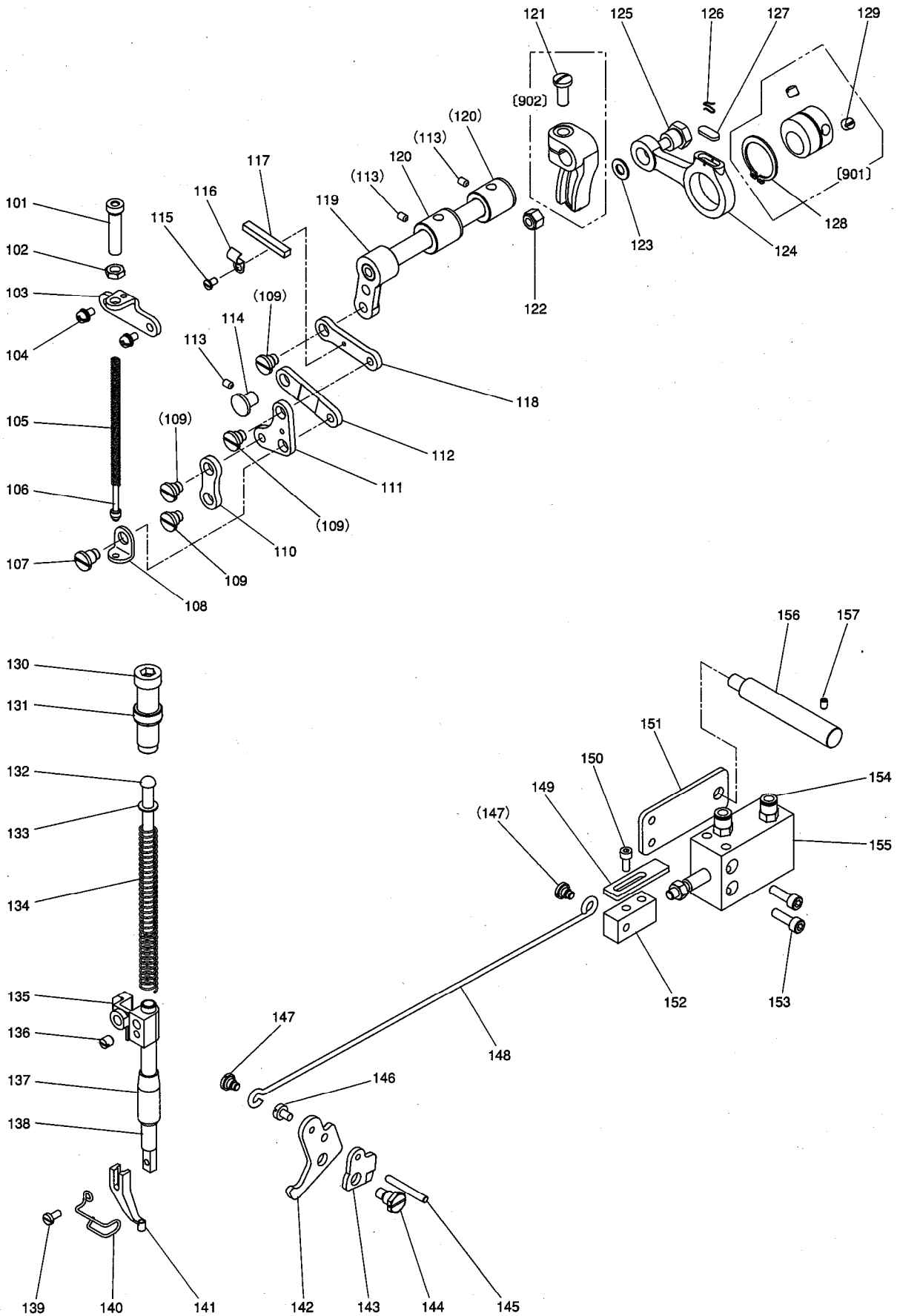

[F] 中押え機構

PRESSER BAR LIFTING MECHANISM

Fig no.	変更 Mod.	部品コード Parts no.	品名	Description	数量	
					5050	10050
F 101		M91801035	ツマミネジ 9/32(28)X35	Thumb screw 9/32(28)X35	1	1
F 102		M91802045	ナット 9/32(28)	Nut 9/32(28)	1	1
F 103		ME10A0261	オサエチヨウセツダイ	Bracket	1	1
F 104		M91056004	SW-PWプラマイナヘネジ M4X10	Screw M4X10	2	2
F 105		ME10A0572	ツルマキハネ	Spring	1	1
F 106		MS03A6154	アンナイガネ	Spring guide bar	1	1
F 107		M91689015	ヒラネジダンツキ 1/4(40)	Screw 1/4(40)	1	1
F 108		MG30B0226	オサエイタササエ	Supporter	1	1
F 109		M91688015	ヒラネジダンツキ 1/4(40)	Screw 1/4(40)	4	4
F 110		ME10A6910	リンク	Link	1	1
F 111		ME10A0763	ベルクランク	Bell crank	1	1
F 112		ME10A7910	リンク	Link	1	1
F 113		M91058020	ロッカクアナツキトメネジ M4X10	Screw M4X10	3	3
F 114		M99006063	ツハツキシク	Pin	1	1
F 115		M90909003	マルヒラネジ 9/64(40)X6	Screw 9/64(40)X6	1	1
F 116		MN70A1780	ホルダ	Holder	1	1
F 117		MG30A0740	フェルト	Felt	1	1
F 118		ME10A1956	レンセツカン	Link	1	1
F 119		MS02E0460	ウデクミタテ	Arm shaft assy	1	1
F 120		MG30A0833	メタル	Bushing	2	2
F 121		M91603003	マルヒラネジ 1/4(40)X16	Screw 1/4(40)X16	1	1
F 122		M91572045	U ナット 6X0.75	U-nut 6X0.75	1	1
F 123		M90631050	ワザガネ 6	Washer 6	1	1
F 124		ME10A0956	レンセツカン	Crank rod	1	1
F 125		M91551015	ホルトダンツキ M6	Bolt M6	1	1
F 126		MF60A0700	センサイクハネ	Holder	1	1
F 127		MG30B0740	フェルト	Felt	1	1
F 128		M90325065	Cガ外メワ 25	C-type retaining ring 25	1	1
F 129		M91606001	トメネジ 1/4(40)X6	Screw 1/4(40)X6	2	2
F 130		M93220035	ツマミネジ 1/2(28)X43	Thumb screw 1/2(28)X43	1	1
F 131		M93202047	ナット 1/2(28)	Nut 1/2(28)	1	1
F 132		MS03A0703	アンナイホウ	Presser bar guide	1	1
F 133		M90632050	ワザガネ 6	Washer 6	1	1
F 134		MS03A1572	ツルマキハネ	Spring	1	1
F 135		MG75A0265	オサエホウダキ	Presser bar holder	1	1
F 136		M91506001	トメネジ 15/64(28)X6	Screw 15/64(28)X6	1	1
F 137		MF10A0267	オサエホウメタル	Bushing	1	1
F 138		MS03A0262	オサエホウ	Presser bar	1	1
F 139		M90922002	ヒラネジ 9/64(40)X8	Screw 9/64(40)X8	1	1
F 140		MB62A0626	ニートルガード	Needle guard	1	1
F 141		MV30A0256	オサエ φ3	Presser foot φ3	1	1
F 142		ME10A1252	オサエアケレバ	Lifting lever	1	1
F 143		MF70A0350	イトユルメカム	Plate cam	1	1
F 144		M91515022	ホルトダンツキ 15/64(28)	Bolt 15/64(28)	1	1
F 145		M90423060	イトユルメピン	Pin	1	1
F 146		M91131002	ヒラネジ 11/64(40)X6.5	Screw 11/64(40)X6.5	1	1
F 147		M91219015	ヒラネジダンツキ 3/16(28)	Screw 3/16(28)	2	2
F 148		ME40A0738	ヒキホウ	Link	1	1
F 149		ME25A0477	ストップ	Stopper	1	1
F 150		M95003017	セフティソケット M5X8	Bolt M5X8	1	1
F 151		ME25A0601	トリツケイタ	Adapter	1	1
F 152		ME25A0571	ジョイント	Joint	1	1
F 153		M95006017	セフティソケット M5X22	Bolt M5X22	1	1
F 154		ME40A0571	ワンタッチツキテ	Connector	1	1
F 155		ME25A0434	エアシリンダ	Air cylinder	1	1
F 156		ME25A1454	ジク	Shaft	1	1
F 157		M95004020	ロッカクアナツキトメネジ M5X8	Screw M5X8	1	1
F 901		MG30A0760	ヘンシンリンクミタテ	Eccentric cam assy	1	1
F 902		MS02A0463	ウデ (ミキ)	Arm (right)	1	1

糸切り機構

THREAD TRIMMING MECHANISM

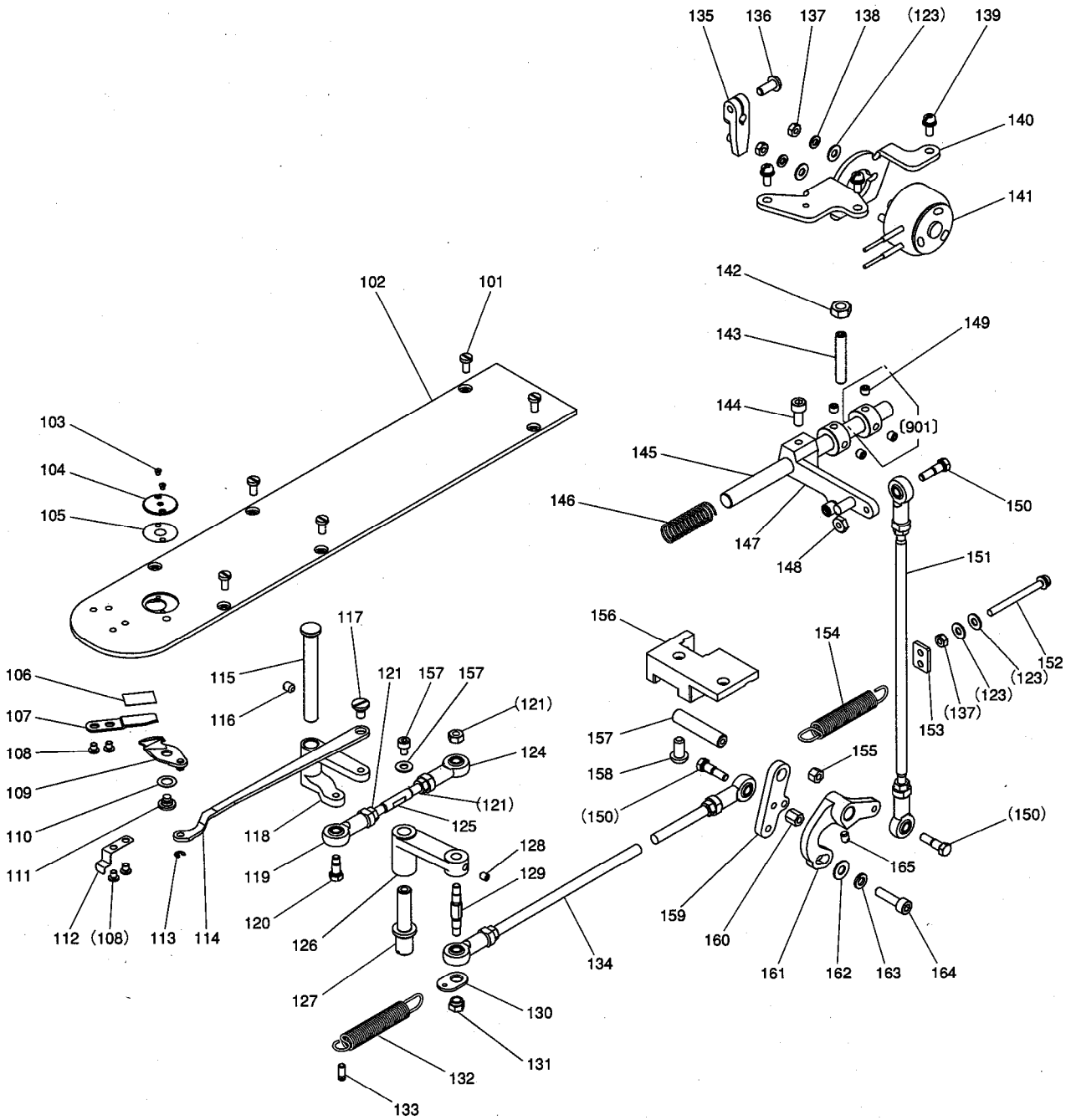

[G]系切り機構

THREAD TRIMMING MECHANISM

Fig no.	変更 Mod.	部品コード Parts no.	品名	Description	数量	
					5050	10050
G 101		M90990002	ヒラネジ M4X8	Screw M4X8	6	6
G 102		MS18A0470	スベリ板	Slide plate	1	1
G 103		M90605010	サネジ 3/32(56)X2.8	Screw 3/32(56)X2.8	2	2
G 104		MS03A1101	ハリ板 φ2.2	Needle plate	1	1
G 105		MS01A1476	スベリサ	Spacer	1	1
G 106		MA10B2476	スベリサ	Spacer	1	1
G 107		MS14A0838	コテメス	Fixed knife	1	1
G 108		M90906003	マルヒラネジ 9/64(40)X3.2	Screw 9/64(40)X3.2	4	4
G 109		MS03B0838	イトメス	Movable knife	1	1
G 110		M96004052	ウェーブワッシャ 6	Wave washer 6	1	1
G 111		M91129015	ヒラネジダンツキ 11/64(40)	Screw 11/64(40)	1	1
G 112		MS01A0192	イタハネ	Leaf spring	1	1
G 113		M90513065	Eカク外メウ 2.5	E-type retaining ring 2.5	1	1
G 114		MA20A1910	リンク	Link	1	1
G 115		MB62A0454	ツバツキシク	Stepped pin	1	1
G 116		M91224001	トメネジ M5X8	Screw M5X8	1	1
G 117		M91214015	ヒラネジダンツキ 3/16(28)	Screw 3/16(28)	1	1
G 118		MA20A0392	メスクトウウデ (3)	Knife driving crank (3)	1	1
G 119		MN55A0975	ロッドエンド	Ball joint	1	1
G 120		M91101017	ボルトダンツキ 11/64(40)	Bolt 11/64(40)	1	1
G 121		M91382045	ナット M5	Nut M5	3	3
G 122		M94001021	ロッカクアナツキボルト M4X6	Bolt M4X6	1	1
G 123		M90421050	ザガネ 4	Washer 4	5	5
G 124		MN72A0975	ロッドエンド	Ball joint	1	1
G 125		M95004023	ウエコミボルト	Stud bolt	1	1
G 126		MA35A1950	レバー	Lever	1	1
G 127		MA20A4454	ツバツキシク	Stepped pin	1	1
G 128		M91050020	ロッカクアナツキトメネジ M4X5	Screw M4X5	1	1
G 129		MA35A2530	ダンツキシク	Shaft	1	1
G 130		MA35A0708	ハネカケ	Hook	1	1
G 131		M91383045	ナット	Nut	1	1
G 132		MA35A1572	ツルマキハネ	Spring	1	1
G 133		M94002067	ミゾツキピン BXカタ φ4X6	Pin φ4X6	1	1
G 134		MB35E0975	ロッドエンドクミタテ	Connecting rod	1	1
G 135		MS01E0430	イトキリサドウウデ	Crank	1	1
G 136		M95049021	ロッカクアナツキボルト M5X12	Bolt M5X12	1	1
G 137		M91007045	ナット M4	Nut M4	3	3
G 138		M90424053	ハネザガネ 4	Spring washer 4	2	2
G 139		M91056004	SW-PWフライナイナネジ M4X10	Screw M4X10	3	3
G 140		MS14A3601	ソレノイドトリツケイタ	Solenoid bracket	1	1
G 141		ME50E0519	イトキリソレノイド	Solenoid (thread trim)	1	1
G 142		M91576045	ナット M6	Nut M6	1	1
G 143		M91652020	コネジ M6X35	Screw M6X35	1	1
G 144		M95003021	ロッカクアナツキボルト M5X12	Bolt M5X12	1	1
G 145		MS01A0348	カムシク	Shaft	1	1
G 146		MS01A1572	ツルマキハネ	Spring	1	1
G 147		MS01E0351	カムツイジュウウデクミ	Cam follower assy	1	1
G 148		M91104045	ナット 11/64(40)	Nut 11/64(40)	1	1
G 149		M95004021	ロッカクアナツキトメネジ M5X5	Screw M5X5	4	4
G 150		M90101017	ボルトダンツキ 11/64(40)	Bolt 11/64(40)	3	3
G 151		MS01E0975	ロッドエンドクミタテ (タテ)	Connecting rod (vertical)	1	1
G 152		M91082004	SW-PWフライナイナネジ M4X45	Screw M4X45	1	1
G 153		MB35A0708	ハネカケ	Hook	1	1
G 154		MA35A0572	ツルマキハネ	Spring	1	1
G 155		M91102045	ナット 11/64(40)	Nut 11/64(40)	1	1
G 156		MS14A3603	トリツケダイ	Bracket	1	1
G 157		MS08A0454	シク	Shaft	1	1
G 158		M96062021	ロッカクアナツキボルト M6X12	Bolt M6X12	2	2
G 159		MS01A2392	メスクトウウデ (2)	Knife driving crank (2)	1	1
G 160		M91109045	ロングナット 11/64(40)	Long nut 11/64(40)	1	1
G 161		MS01A1392	メスクトウウデ (1)	Knife driving crank (1)	1	1
G 162		M90511050	ザガネ 5	Washer 5	1	1
G 163		M90504053	ハネザガネ 5	Spring washer 5	1	1
G 164		M95015021	ロッカクアナツキボルト M5X20	Bolt M5X20	1	1
G 165		M91108001	トメネジ 11/64(40)X5.5	Screw 11/64(40)X5.5	1	1
G 901		MS01A3352	カラークミ	Collar assy	2	2

From the library of: Diamond Needle Corp

☐ 糸緩め機構
TENSION RELEASE MECHANISM

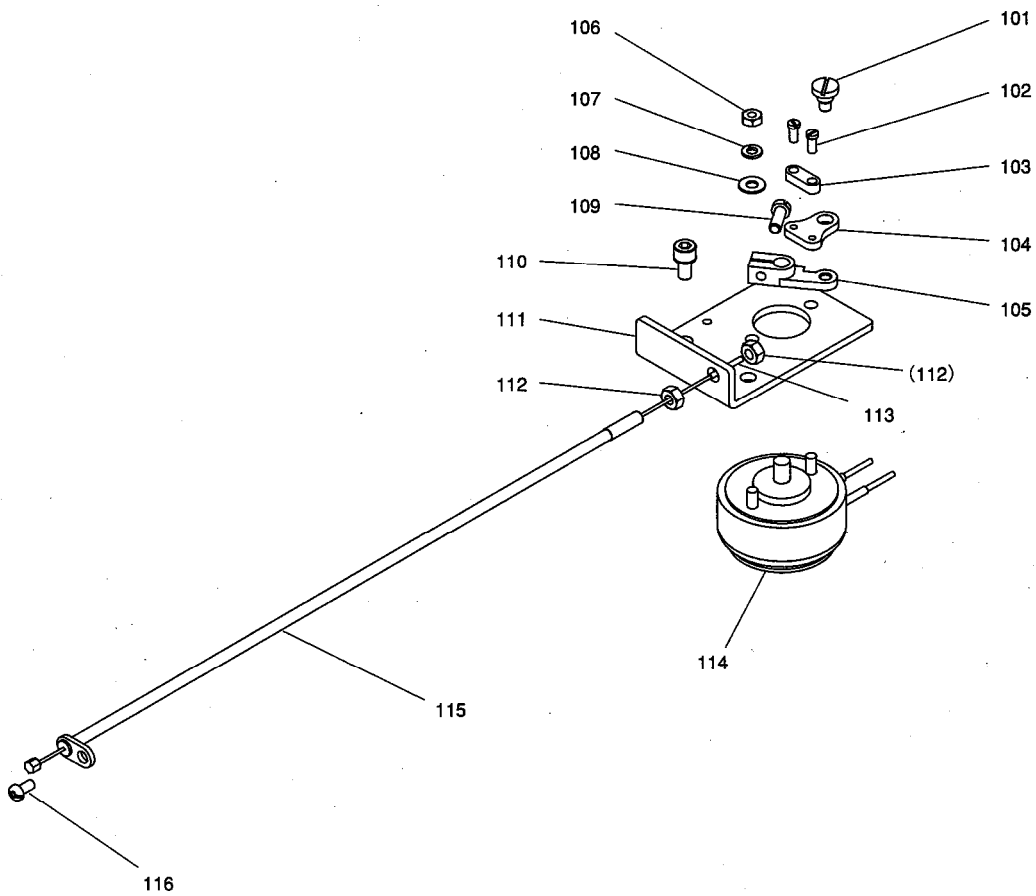

From the library of: Diamond Needle Corp

[H]系緩め機構

TENSION RELEASE MECHANISM

Fig no.	変更 Mod.	部品コード Parts no.	品名	Description	数量	
					5050	10050
H 101		M91127015	ヒラネジダツキ 11/64(40).....	Screw 11/64(40).....	1	1
H 102		M90802002	ヒラネジ 1/8(44)X7.....	Screw 1/8(44)X7.....	2	2
H 103		MF36A0750	ホルダ.....	Holder.....	1	1
H 104		MF90A0361	カケガネ.....	Bracket.....	1	1
H 105		MS07A0228	ウデ.....	Crank.....	1	1
H 106		M91007045	ナット M4.....	Nut M4.....	2	2
H 107		M90424053	バネサガネ 4.....	Spring washer 4.....	2	2
H 108		M90421050	サガネ 4.....	Washer 4.....	2	2
H 109		M91112002	ヒラネジ 11/64(40)X12.....	Screw 11/64(40)X12.....	1	1
H 110		M95005017	セフティソケット M5X10.....	Bolt M5X10.....	2	2
H 111		MA20A0603	ソレノイドトリツケイタ.....	Solenoid bracket.....	1	1
H 112		M91382045	ナット M5.....	Nut M5.....	2	2
H 113		MN60A0750	プッシュ.....	Pipe.....	1	1
H 114		ME50E1519	イトルメソレノイド.....	Solenoid (thread release).....	1	1
H 115		ME40E0746	フレキシブルワイヤ.....	Flexible wire assy.....	1	1
H 116		M91054004	プラマイナベネジ M4X8.....	Screw M4X8.....	1	1

J X-Yテーブル機構 (I)
 X-Y TABLE MECHANISM (I)

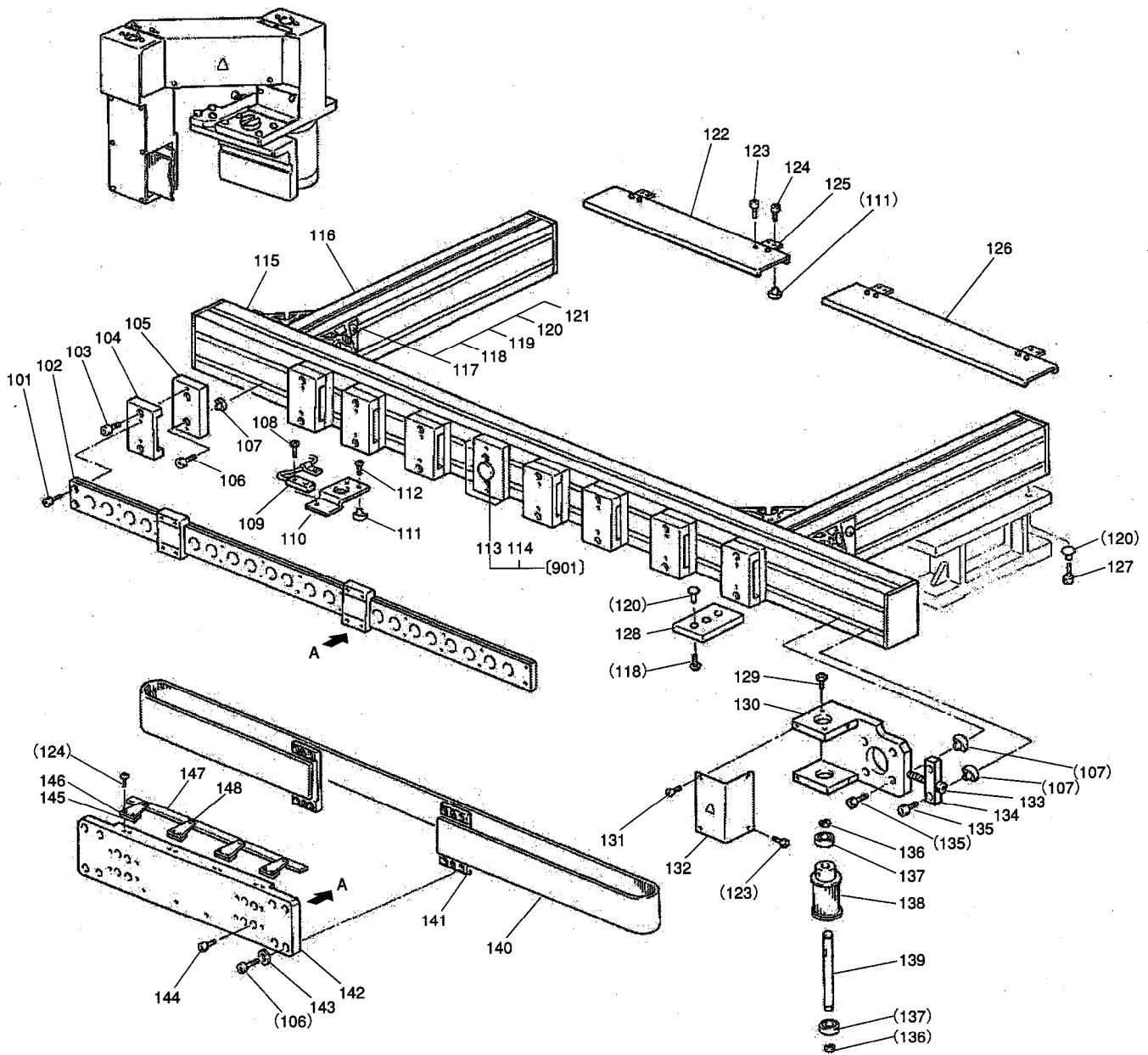

[J]X-Yテーブル機構(I)
WORK HOLDER MECHANISM(I)

Fig no.	変更 Mod.	部品コード Parts no.	品 名	Description	数量	
					5050	10050
J 101		M94003021	ロッカアナツキボルト M4X12	Bolt M4X12	18	26
J 102		MB50A2920	スライドガイド X	Slide guide X	1	*
J 102		MB15A2920	スライドガイド X	Slide guide X	*	1
J 103		M95004017	セフティソケット M5X16	Bolt M5X16	18	26
J 104		MB50A0743	アッパープレート	Upper plate	9	13
J 105		MB50A1743	ロープレート (A)	Lower plate (A)	8	10
J 106		M95002017	セフティソケット M5X12	Bolt M5X12	31	38
J 107		M95001047	Tナット M5	T-nut M5	28	36
J 108		M90971004	SW-PWプラマイナネジ M3X10	Screw M3X10	1	1
J 109		ME50A0484	キンセツスイッチ X	Detector X	1	1
J 110		ME50A0601	センサートリツケイタ X	Detector holder X	1	1
J 111		M94003047	Tナット M4	T-nut M4	2	2
J 112		M91059004	SW-PWプラマイナネジ M4X12	Screw M4X12	2	2
J 113		MB50A0419	キューションパッド	Vibration preventing pad	1	3
J 114		MB50A2743	ロープレート (B)	Lower plate (B)	1	3
J 115		MB50A0413	Xジクコラム	X-column	1	*
J 115		MB15A0413	Xジクコラム	X-column	*	1
J 116		MB50A1413	Yジクコラム	Y-column	2	2
J 117		MB50A0571	コーナージョイント	Corner joint	3	4
J 118		M98018022	ロッカアナツキボルト M8X16	Bolt M8X16	16	18
J 119		M96006052	カクザガネ	Square washer	10	12
J 120		M98605047	Tナット M8	T-nut M8	36	42
J 121		M98003017	セフティソケット M8X16	Bolt M8X16	12	16
J 122		MB50A0339	Xジクカバー (L)	X-column cover (left)	1	*
J 122		MB15A0339	Xジクカバー (L)	X-column cover (left)	*	1
J 123		M91058004	SW-PWプラマイナネジ M4X6	Screw M4X6	10	14
J 124		M91073004	SW-PWプラマイナネジ M4X16	Screw M4X16	16	20
J 125		MB50A0426	ササエカナゲ	Bracket	4	6
J 126		MB50B0339	Xジクカバー (R)	X-column cover (right)	1	*
J 126		MB15B0339	Xジクカバー (R)	X-column cover (right)	*	1
J 127		M98004017	セフティソケット M8X20	Bolt M8X20	8	8
J 128		MB50A0196	X-Yコラムイチキメータ	X-Y column holder	2	2
J 129		M91071004	SW-MWプラマイナネジ M4X8	Screw M4X8	4	4
J 130		MB50A0758	ブラケット X	Bracket X	1	1
J 131		M91064004	サラネジ M4X6	Screw M4X6	2	2
J 132		MB50A1339	プーリカバークミタテ	Pulley cover complete	1	1
J 133		M95011021	ロッカアナツキボルト M5X25	Bolt M5X25	1	1
J 134		MA30A0751	テンションブロック	Tension block	1	1
J 135		M95001017	セフティソケット M5X20	Bolt M5X20	6	6
J 136		M90510065	C型外メテ 10	C-type retaining ring 10	2	2
J 137		MB50A0456	ベアリング	Ball bearing	2	2
J 138		MB50A0767	タイミングプーリ	Cog pulley	1	1
J 139		MS05A0454	ジク	Shaft	1	1
J 140		MB50A0523	タイミングベルト X	Cog belt X	1	*
J 140		MB15A0523	タイミングベルト X	Cog belt X	*	1
J 141		MB50A0778	ベルトオサエクミタテ	Belt clamp assy	2	2
J 142		ME50A0957	Xイトウレース	X-movable race	1	1
J 143		M90512050	コサガネ 5	Washer 5	8	8
J 144		M94007017	セフティソケット M4X12	Bolt M4X12	8	8
J 145		MB50A0476	スペーサ	Spacer	4	4
J 146		MB50A1601	トリツケイタ	Detector plate support	4	4
J 147		MB50A0407	ケンシュツイタ X	Detector plate X	1	1
J 148		M91305010	サラネジ M3X4	Screw M3X4	4	4
J 901		MB50E3743	ホウシツキロープレート	Vibration preventing lower plate	1	3

☑ X-Yテーブル機構(Ⅱ)
X-Y TABLE MECHANISM(Ⅱ)

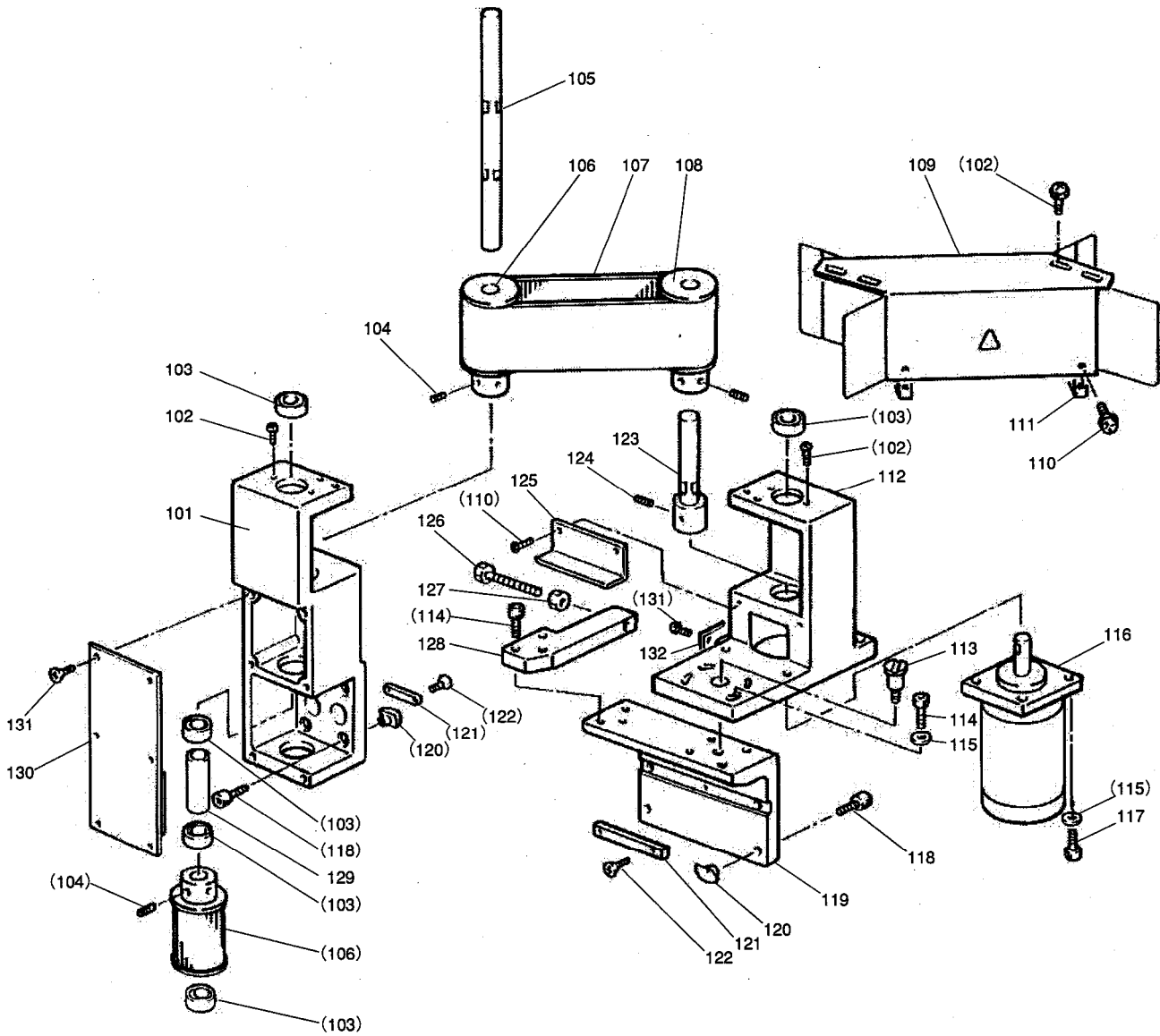

[K]X-Yテーブル機構(Ⅱ)
WORK HOLDER MECHANISM(Ⅱ)

Fig no.	変更 Mod.	部品コード Parts no.	品名	Description	数量	
					5050	10050
K 101		MB50A1758	ブラケット X	Bracket X	1	1
K 102		M91071004	SW-PWプライマインネジ M4X8	Screw M4X8	12	12
K 103		MB50A0456	ベアリング	Ball bearing	6	6
K 104		M96001001	トメネジ M6X8	Screw M6X8	6	6
K 105		MB50A0390	Xドライブシャフト (B)	X-drive shaft (B)	1	1
K 106		MB50A1767	タイミングプーリー	Cog pulley	2	2
K 107		MB50A1523	タイミングベルト	Cog belt	1	1
K 108		MB50A2767	タイミングプーリー	Cog pulley	1	1
K 109		MB50E0776	ベルトカバークミタテ	Belt cover assy	1	1
K 110		M91058004	SW-PWプライマインネジ M4X6	Screw M4X6	6	6
K 111		MB50A0226	カバーウケガネ	Cover adapter	2	2
K 112		MB50A2758	ブラケット (モータX)	Bracket (motor-X)	1	1
K 113		MB50A0454	ツハツキシク	Shaft	1	1
K 114		M95008017	セフティソケット M5X25	Bolt M5X25	7	7
K 115		M90511050	ミカキザガネ 5	Washer 5	8	8
K 116		M95053095	ステップینگモータクミタテ X	Motor complete X	1	1
K 117		M95004017	セフティソケット M5X16	Bolt M5X16	4	4
K 118		M95002017	セフティソケット M5X12	Bolt M5X12	8	8
K 119		MB50A0603	モータリツケダイ	Motor bracket	1	1
K 120		M95001047	Tナット M5	T-nut M5	8	8
K 121		MB50A0370	キー	Key	2	2
K 122		M90830004	SW-PWプライマインネジ M3X10	Screw M3X10	2	2
K 123		MB50A1390	Xドライブシャフト (A)	X-drive shaft (A)	1	1
K 124		M96002001	トメネジ M6X6	Screw M6X6	2	2
K 125		MB50A0849	Xモータカバー	X-motor cover	1	1
K 126		M96029021	ロッククアナツキボルト M6X45	Bolt M6X45	1	1
K 127		M91576045	ロックナット M6	Nut M6	1	1
K 128		MB50A0751	テンションブロック	Tension block	1	1
K 129		MB50A0352	カラー	Collar	1	1
K 130		MB50A2339	プーリカバークミタテ (A)	Pulley cover complete	1	1
K 131		M91064004	サラネジ M4X6	Screw M4X6	10	10
K 132		MB50A0161	アテガネ	Plate	1	1

□ X-Yテーブル機構(Ⅲ)
 X-Y TABLE MECHANISM(Ⅲ)

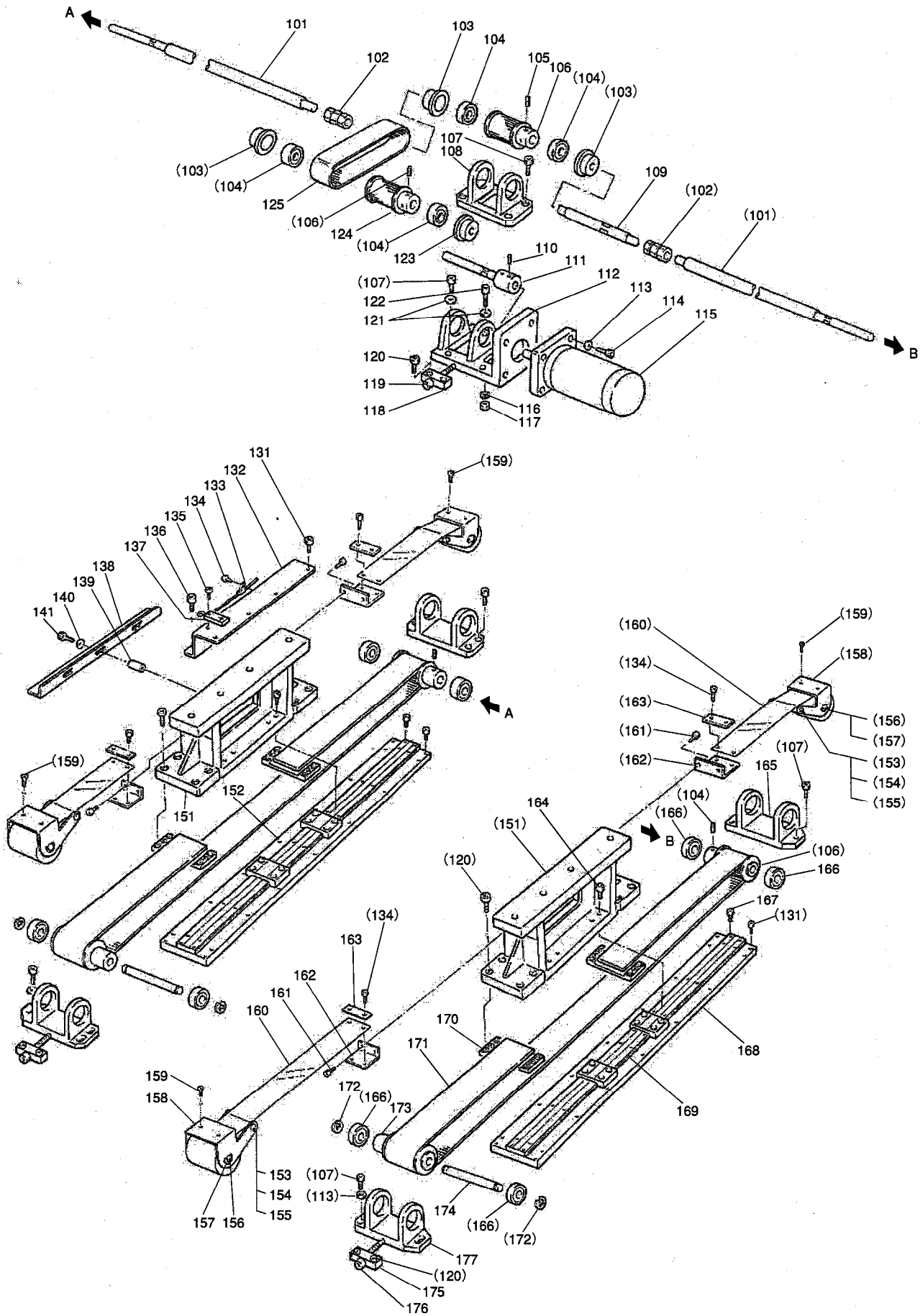

[L]X-Yテーブル機構(Ⅲ)
WORK HOLDER MECHANISM(Ⅲ)

Fig no.	変更 Mod.	部品コード Parts no.	品名	Description	数量	
					5050	10050
L 101		MB50A2390	Yクトウシク (B).....	Y-drive shaft (B).....	2	2
L 102		MA30A0364	ナカカップリング.....	Coupling.....	2	2
L 103		MB50A0165	ベアリングアダプタ (B).....	Bearing adapter (B).....	3	3
L 104		MB50A0456	ベアリング.....	Ball bearing.....	4	4
L 105		M96001001	トメネジ M6X8.....	Screw M6 × 8.....	8	8
L 106		MB50A1767	タイミングプーリ.....	Cog pulley.....	3	3
L 107		M96005017	セフティソケット M6X25.....	Bolt M6X25.....	19	19
L 108		MB50A5758	チュウカンブラケット.....	Bracket.....	1	1
L 109		MB50A3390	Yクトウシク (A).....	Y-drive shaft (A).....	1	1
L 110		M96002001	トメネジ M6X6.....	Screw M6X6.....	4	4
L 111		MB50A4390	Yクトウシクミタテ.....	Y-drive shaft complete.....	1	1
L 112		MB50A3758	ブラケット (モータ).....	Motor bracket.....	1	1
L 113		M90631050	ミカキザガネ 6.....	Washer 6.....	10	10
L 114		M96006017	セフティソケット M6X20.....	Bolt M6X20.....	4	4
L 115		M95054095	ステッピングモータミタテ Y.....	Motor complete Y.....	1	1
L 116		M90624053	ハネザガネ 6.....	Washer 6.....	1	1
L 117		M91576045	ロックナット M6.....	Nut M6.....	1	1
L 118		MA30A0751	テンションブロック.....	Tension block.....	1	1
L 119		M95006021	ロックアナツキボルト M5X30.....	Bolt M5X30.....	1	1
L 120		M95001017	セフティソケット M5X20.....	Bolt M5X20.....	22	22
L 121		M93002052	ザガネ.....	Special washer.....	4	4
L 122		M96015021	ロックアナツキボルト M6X40.....	Bolt M6X40.....	1	1
L 123		MB50A1165	ベアリングアダプタ (A).....	Bearing adapter (A).....	1	1
L 124		MB50A2767	タイミングプーリ.....	Cog pulley.....	1	1
L 125		MB50A2523	タイミングベルト.....	Cog belt.....	1	1
L 131		M95004017	セフティソケット M5X16.....	Bolt M5X16.....	32	32
L 132		ME50A1601	センサートリツケイタ Y.....	Detector holder Y.....	1	1
L 133		MB50A0620	ナイロンクリップ.....	Nylon clip.....	1	1
L 134		M91054004	SW-PWブラマイナヘネジ M4X8.....	Screw M4X8.....	1	1
L 135		M90971004	SW-PWブラマイナヘネジ M3X10.....	Screw M3X10.....	1	1
L 136		M95003017	セフティソケット M5X8.....	Bolt M5X8.....	4	4
L 137		ME50A1484	キンセツスイッチ Y.....	Detector Y.....	1	1
L 138		MB50A1407	ケンジュツイタ Y.....	Detector plate Y.....	1	1
L 139		MB50A1476	スペーサ.....	Spacer.....	3	3
L 140		M90511050	ミカキザガネ 5.....	Washer 5.....	3	3
L 141		M95008017	セフティソケット M5X25.....	Bolt M5X25.....	3	3
L 151		MB50A1957	Yイトウレース.....	Y-movable race.....	2	2
L 152		MB50A0922	リニアトリツケイタ (L).....	Linear way adapter (left).....	1	1
L 153		MB50A0971	ローラシク.....	Roller shaft.....	1	1
L 154		M90504065	Eガ外メワ 4.....	E-type retaining ring 4.....	2	2
L 155		MB50A0972	ガイドローラ.....	Guide roller.....	1	1
L 156		MB50A2454	ドラムシャフト.....	Drum shaft.....	1	1
L 157		M90604065	Eガ外メワ 8.....	E-type retaining ring 8.....	2	2
L 158		MB50A4758	ブラケットミタテ.....	Bracket assy.....	1	1
L 159		M91064004	サラネジ M4X6.....	Screw M4X6.....	4	4
L 160		MB50A0421	カバーヨウコンストクミタテ.....	Cover assy.....	1	1
L 161		M94001017	セフティソケット M4X10.....	Bolt M4X10.....	8	8
L 162		MB50A1226	カバーウケダイ.....	Cover adapter.....	4	4
L 163		M96007052	カクザガネ.....	Square washer.....	4	4
L 164		M94006017	セフティソケット M4X16.....	Bolt M4X16.....	16	16
L 165		MA70A2758	ブラケット.....	Bracket.....	2	2
L 166		MS05A0456	ベアリング (トメワツキ).....	Ball bearing.....	8	8
L 167		M94007017	セフティソケット M4X12.....	Bolt M4X12.....	32	32
L 168		MB50A1922	リニアトリツケイタ (R).....	Linear way adapter (right).....	1	1
L 169		MB50A3920	スライドガイド Y.....	Slide guide Y.....	2	2
L 170		MB50A0778	ベルトオサエクミタテ.....	Belte clamp assy.....	4	4
L 171		MB50A3523	タイミングベルト.....	Cog belt.....	2	2
L 172		M90510065	Cガ外メワ 10.....	C-type retaining ring 10.....	4	4
L 173		MB50A0767	タイミングプーリ.....	Cog pulley.....	2	2
L 174		MS05A0454	シク.....	Shaft.....	2	2
L 175		MB50A1751	テンションブロック.....	Tension block.....	2	2
L 176		M95011021	ロックアナツキボルト M5X25.....	Bolt M5X25.....	2	2
L 177		MB50A6758	ブラケット.....	Bracket.....	2	2

M 外押え機構
 WORK HOLDER MECHANISM

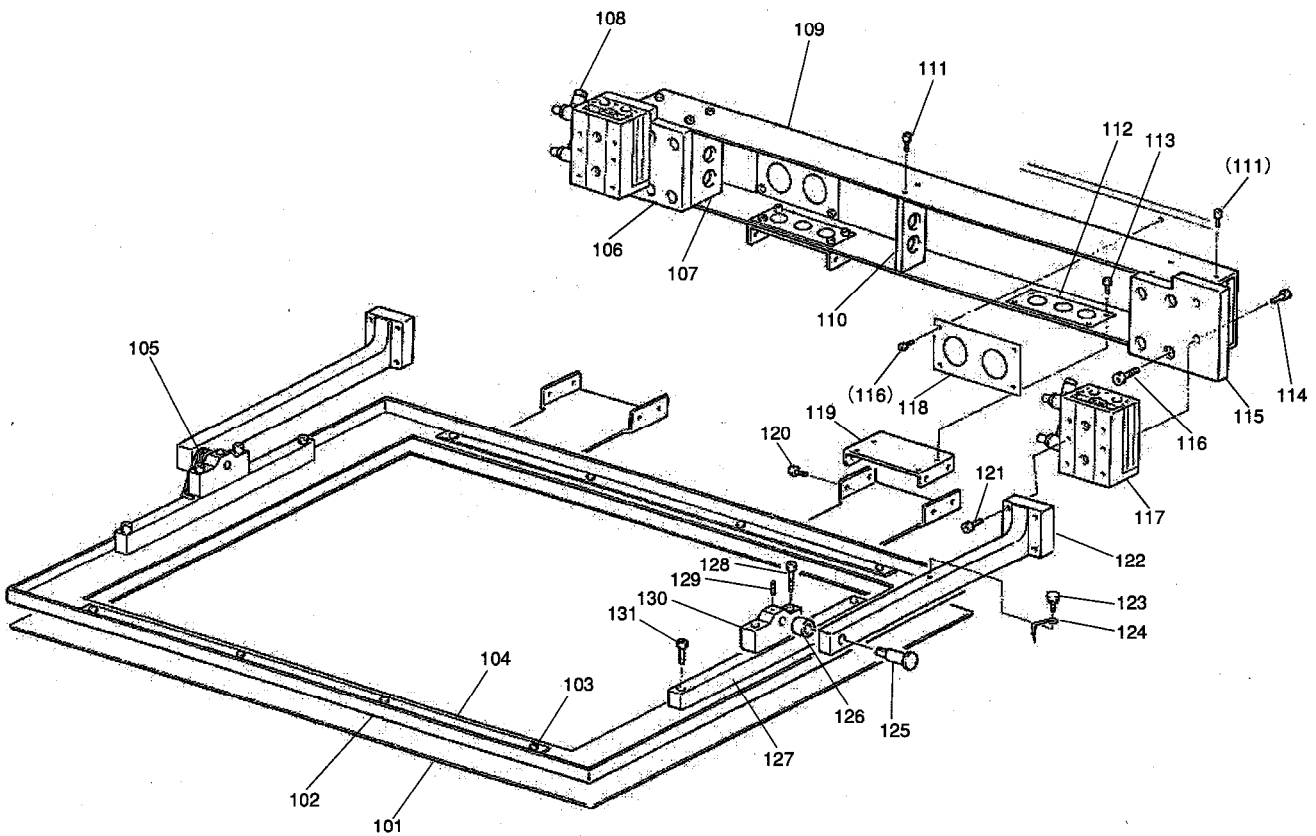

注) この部分は外押え機構付電子ミシンに適用します。

Note : These parts are applied for a machine shipped with a standard clamp.

[M]外押え機構

WORK HOLDER MECHANISM

Fig. no.	変更 Mod.	部品コード Parts no.	品名	Description	数量	
					5050	10050
M 101		MB50A0272	シタオサエイタ	Feed plate	1	*
M 101		MB15A0272	シタオサエイタ	Feed plate	*	1
M 102		MB50A0105	オサエ	Clamp frame	1	*
M 102		MB15A0105	オサエ	Clamp frame	*	1
M 103		M91330004	SW-PWプラマイナネジ M5X8	Screw M5X8	8	8
M 104		MB50A0799	オサエホキョウイタ	Stiffening plate	2	2
M 105		MB50A0557	ネジリコイルバネ	Spring	1	1
M 106		MB50A3601	オサエトリツケイタ (L)	Adapter (left)	1	1
M 107		MB50A0780	オサエホルダー	Clamp holder	2	2
M 108		MS45A0497	スピードコントローラ	Speed controller	4	4
M 109		MB50A0308	オサエタイ	Clamp bracket	1	*
M 109		MB15A0308	オサエタイ	Clamp bracket	*	1
M 110		MB50A1426	サポート	Support block	1	1
M 111		M94007017	セフティソケット M4X12	Bolt M4X12	20	24
M 112		M96008052	カクザガネ	Square washer	2	2
M 113		M94001017	セフティソケット M4X10	Bolt M4X10	8	8
M 114		M95002017	セフティソケット M5X12	Bolt M5X12	4	4
M 115		MB50A4601	オサエトリツケイタ (R)	Adapter (right)	1	1
M 116		M95004017	セフティソケット M5X16	Bolt M5X16	8	8
M 117		MB50A0595	エアスライドテーブル	Air slide table	2	2
M 118		M96009052	ホキョウカクザガネ	Stiffening washer	2	2
M 119		MB50A5601	シタオサエトリツケイタ	Feed plate bracket	2	2
M 120		M94008017	セフティソケット M4X6	Bolt M4X6	8	8
M 121		M94006017	セフティソケット M4X16	Bolt M4X16	8	8
M 122		ME50A0273	オサエウテ	Clamp adapter	2	2
M 123		MA20A0650	ナールトノブ	Knurled Knobs	1	1
M 124		MB50A0477	ストッパ	Stopper	1	1
M 125		MB50A1454	ジク	Clamp stud	2	2
M 126		MB50A0352	カラー	Collar	2	2
M 127		MB50A2426	オサエサポート	Clamp supporter	2	2
M 128		M95001017	セフティソケット M5X20	Bolt M5X20	4	4
M 129		M91056020	ロッククアナツキメネジ M4X6	Screw M4X6	2	2
M 130		MB50A3426	ササエ	Supporter	2	2
M 131		M95003017	セフティソケット M5X8	Bolt M5X8	6	6

N
 ワイパー機構
 WIPER MECHANISM

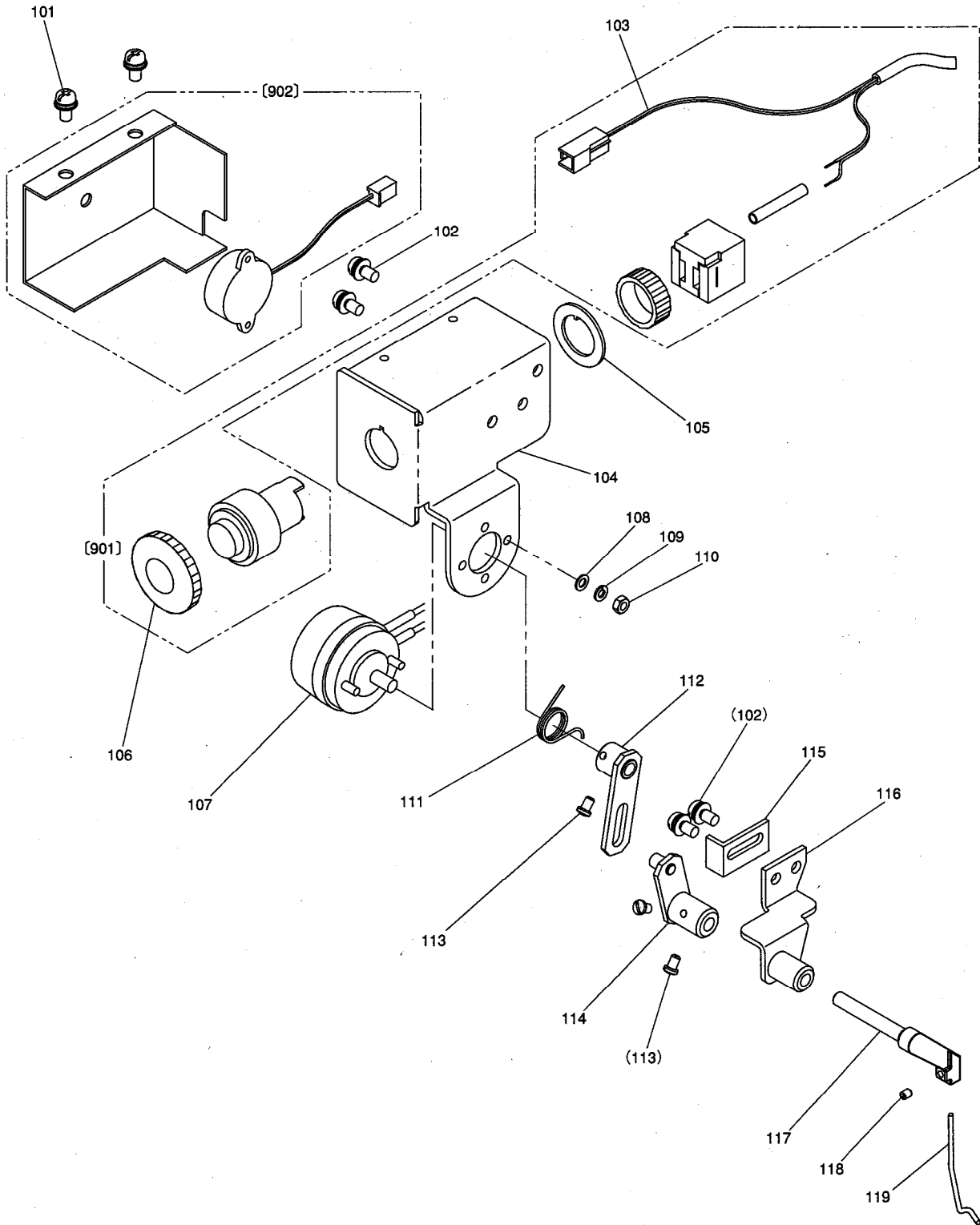

From the library of: Diamond Needle Corp

[N]ワイパー機構
WIPER MECHANISM

Fig no.	変更 Mod.	部品コード Parts no.	品名	Description	数量	
					5050	10050
N 101		M91054004	SW-PWプライマインナネジ M4X8	Screw M4X8	2	2
N 102		M91056004	SW-PWプライマインナネジ M4X10	Screw M4X10	4	4
N 103		ME50A0508	セツゾクデンセン	Cable (stop BZ)	1	1
N 104		ME10E3601	トリツケイタ	Bracket	1	1
N 105		MB60A0915	ロックリング	Lock ring	1	1
N 106		ME03A0270	プッシュボタン	Push button	1	1
N 107		ME50E2519	ワイパーソレノイド	Solenoid (wiper)	1	1
N 108		M90317050	ザガネ 3	Washer 3	2	2
N 109		M90307053	ハネザガネ 3	Spring washer 3	2	2
N 110		M90875045	ナット M3	Nut M3	2	2
N 111		MS02A4729	ヒネリバネ	Spring	1	1
N 112		MS02E0983	クドウイタ	Wiper crank 1	1	1
N 113		M90802003	マルヒラネジ 1/8(44)X4.5	Screw 1/8(44)X4.5	4	4
N 114		MB01A0436	ジュウトウイタ	Wiper crank 2	1	1
N 115		MS02A1477	ストッパ	Stopper	1	1
N 116		MS10A0982	ワイパーダイ	Wiper adapter	1	1
N 117		MS03A1530	ワイパーシャフト	Wiper shaft	1	1
N 118		M91057020	ロッククアナツキメネジ M3X4	Screw M3X4	1	1
N 119		MA20A0980	ワイパー	Wiper	1	1
N 901		ME50E0270	オンボタンスイッチタミ	Switch assy	1	1
N 902		MB60E3339	カバータミ (ブザーツキ)	Cover assy (with buzzer)	1	1

給油機構

OIL LUBRICATION MECHANISM

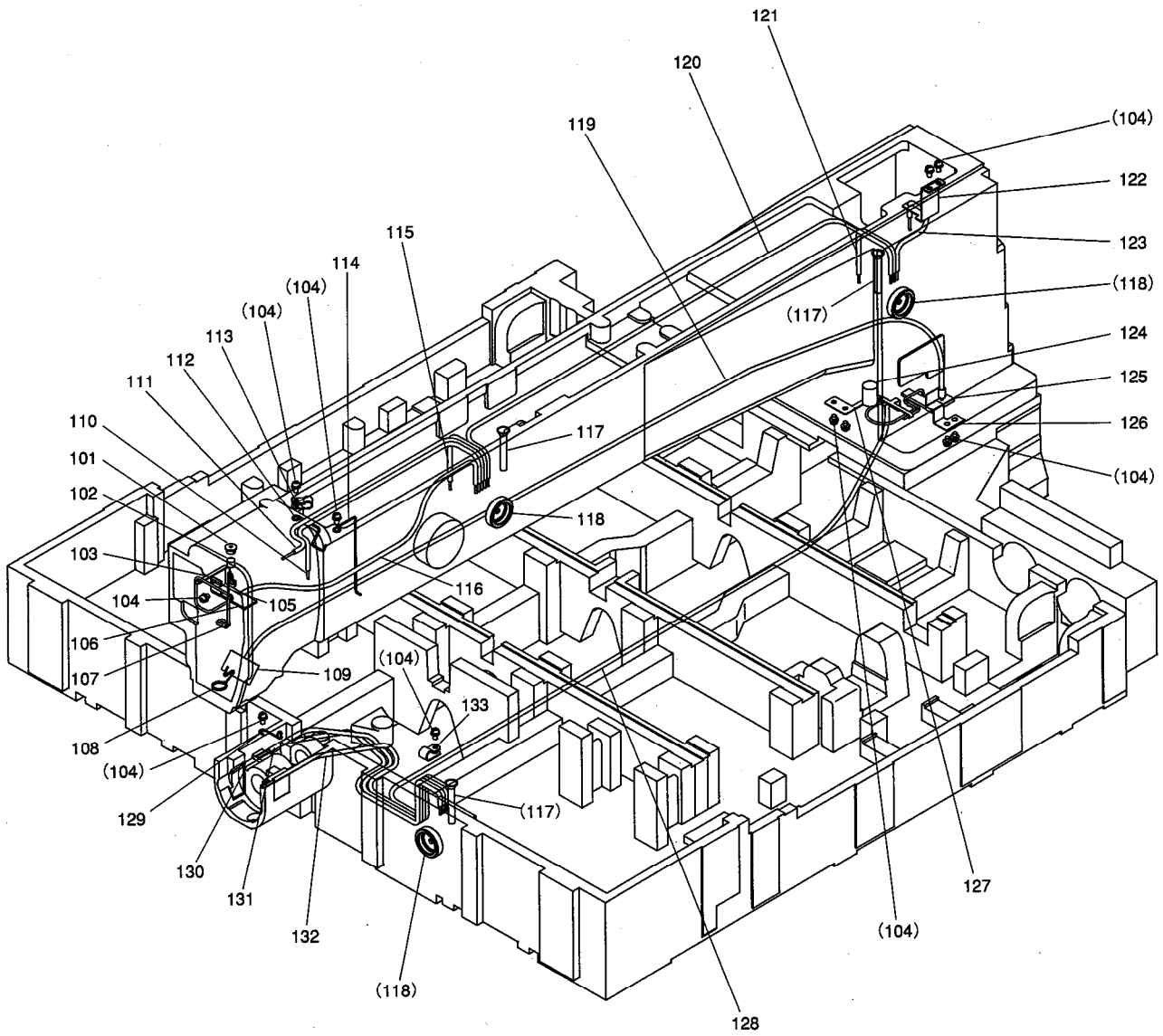

From the library of: Diamond Needle Corp

[P]給油機構

OIL LUBRICATION MECHANISM

Fig no.	変更 Mod.	部品コード Parts no.	品名	Description	数量	
					5050	10050
P 101	MF60A0742		フタ	Cap	1	1
P 102	MF10A2740		フェルト	Felt	1	1
P 103	ME10A1780		ホルダ	Holder	1	1
P 104	M91054004		SW-PWブライナネジ M4X8	Screw M4X8	11	11
P 105	MS03A2780		ホルダ	Holder	1	1
P 106	MS01A1740		フェルト	Felt	1	1
P 107	MF80A0780		ホルダ	Holder	1	1
P 108	MF00A2780		ホルダ	Holder	1	1
P 109	MS08A0740		フェルト	Felt	1	1
P 110	ME40E9688		パイプヒモクミ (ヘンシンリン)	Oil pipe assy (eccentric cam)	1	1
P 111	ME40E7688		パイプヒモクミ (ウワジクメタル マエ)	Oil pipe assy (drive shaft bushing F)	1	1
P 112	MA20A1780		ホルダ	Holder	1	1
P 113	MS14A1620		ナイロンクリップ AB-4N	Nylon clip AB-4N	1	1
P 114	MS10A0780		ホルダ	Holder	1	1
P 115	ME40F1688		パイプヒモクミ (ウワジクメタル ナカ)	Oil pipe assy (drive shaft bushing C)	1	1
P 116	ME40E6688		パイプヒモクミ (ハリホウ)	Oil pipe assy (needle bar)	1	1
P 117	MA20A6688		パイプ (アルミ)	Pipe	3	3
P 118	MN10A0135		オイルゲージ	Oil gauge	3	3
P 119	ME40E4688		パイプヒモクミ (カンユ)	Oil pipe assy (circulation)	1	1
P 120	ME40F0688		パイプヒモクミ (タンク)	Oil pipe assy (tank)	1	1
P 121	ME40E8688		パイプヒモクミ (ウワジクメタル ウシロ)	Oil pipe assy (drive shaft bushing R)	1	1
P 122	MB60A1780		ホルダ	Holder	1	1
P 123	ME40E3688		パイプヒモクミ (レンゼツカン)	Oil pipe assy (connecting rod)	1	1
P 124	MF60A5740		フェルト	Felt	1	1
P 125	MS14A0740		フェルト	Felt	1	1
P 126	MS01A9796		ホルダ	Holder	1	1
P 127	MS14A3780		ホルダ	Holder	1	1
P 128	ME40E5688		パイプヒモクミ (シタジクメタル ウシロ)	Oil pipe assy (hook shaft bushing R)	1	1
P 129	MS01A8796		ホルダ	Holder	1	1
P 130	ME40E1688		パイプヒモクミ (カマ ヒタリ)	Oil pipe assy (hook left)	1	1
P 131	ME40E2688		パイプヒモクミ (カマ ナカ)	Oil pipe assy (hook center)	1	1
P 132	ME40E0688		パイプヒモクミ (カマ ミキ)	Oil pipe assy (hook right)	1	1
P 133	MN60A0620		ナイロンクリップ AB-5N	Nylon clip AB-5N	1	1

□ 配線・配管関係

CABLE COMPONENT & PNEUMATIC CONTROL UNIT

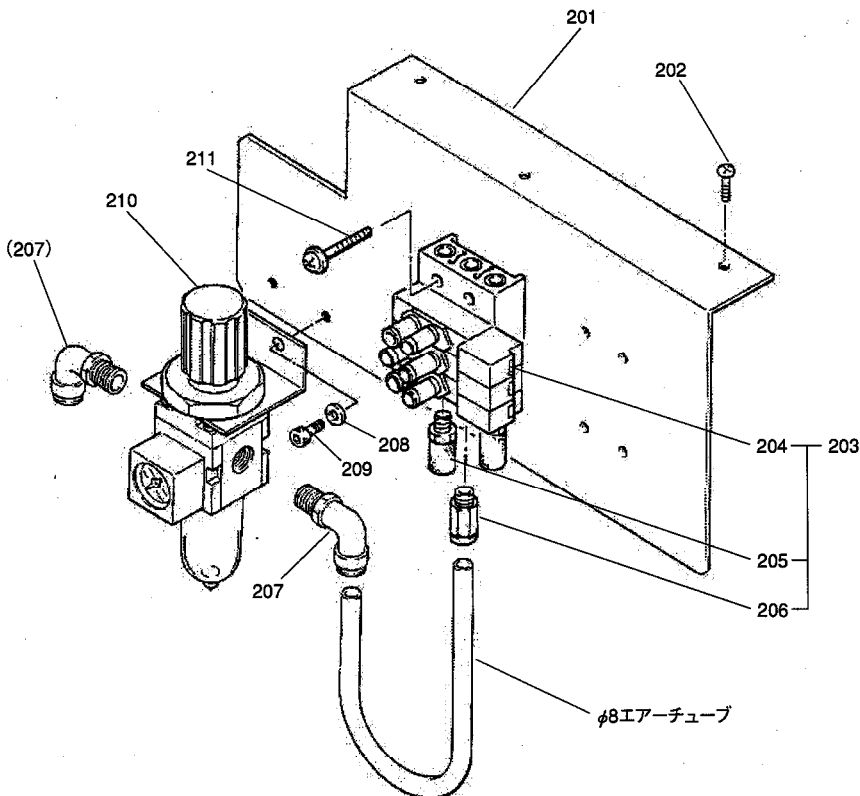
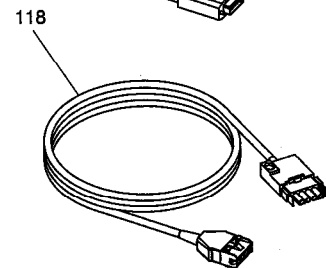
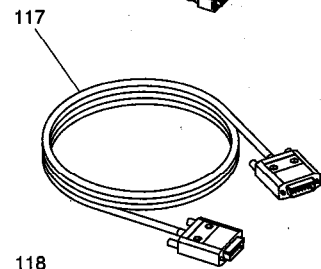
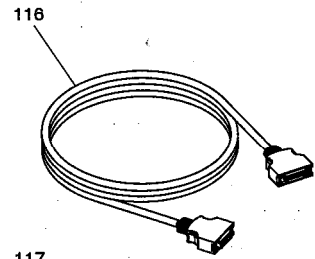
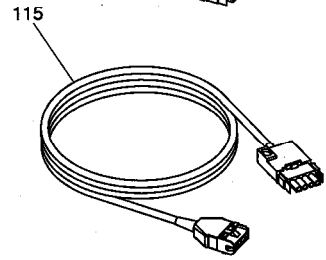
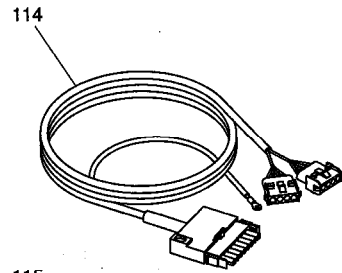
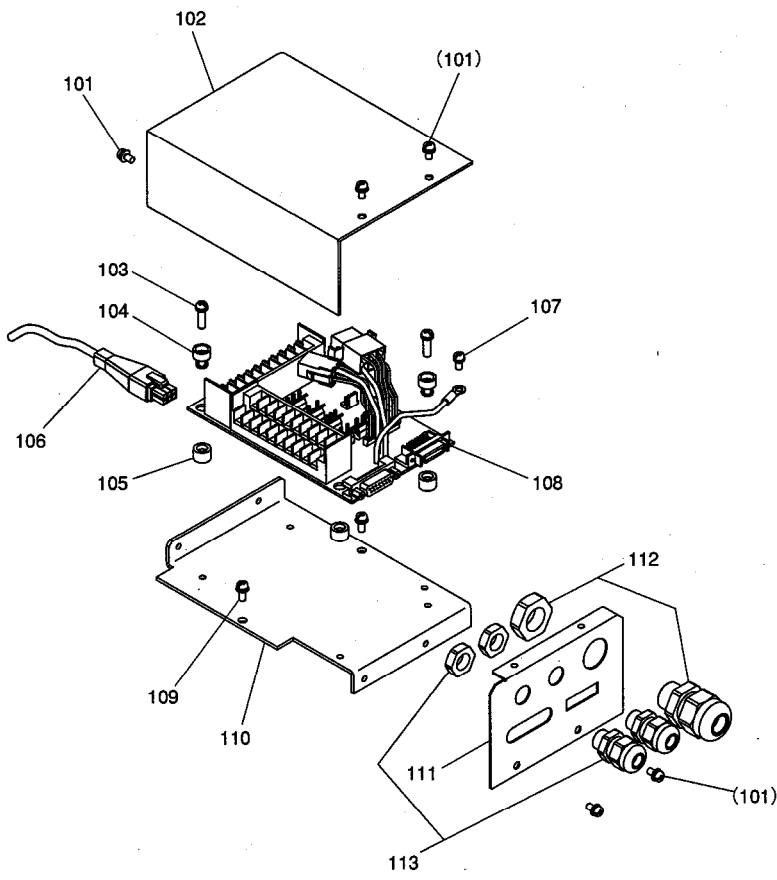

[Q]配線・配管関係

CABLE COMPONENT & PNEUMATIC CONTROL UNIT

Fig no.	変更 Mod.	部品コード Parts no.	品名	Description	数量	
					5050	10050
Q 101		M91071004	SW-MWブラマイナヘネジ M4X8	Screw M4X8	7	7
Q 102		MB50A3339	Pハンカハ	Circuit board cover	1	1
Q 103		M91073004	SW-PWブラマイナヘネジ M4X16	Screw M4X16	4	4
Q 104		MB60A0366	ワンタッチブッシュ	Nylon bush	4	4
Q 105		MB60A2352	ワンタッチブッシュ	Nylon bush	4	4
Q 106		K14M71725402	ケーブル (エンコーダ)	Cable (Encoder)	1	1
Q 107		M90439037	SWブラマイナヘネジ M4X8	Screw M4X8	1	1
Q 108		M800E1CON	Pハンクミタテ PLK-E-CON	Print circuit board	1	1
Q 109		M91056004	SW-PWブラマイナヘネジ M4X10	Screw M4X10	2	2
Q 110		MB65A0601	Pハントリツケイタ	Circuit board bracket	1	1
Q 111		MB60A5601	コネクタトリツケイタ	Connector panel	1	1
Q 112		MB60A5780	コードブッシュ タイ	Cord bushing (large)	1	1
Q 113		MB60A6780	コードブッシュ ショウ	Cord bushing (small)	2	2
Q 114		M97321099	ケーブル (ステッピングモータ)	Cable (stepping motor)	1	1
Q 115		ME50A1508	ケーブル (ステッピングモータエンチャウヨウ)	Cable (stepping motor extension)	1	1
Q 116		M97319099	ケーブル (ニューリヨクシンゴウ)	Cable (input signal)	1	1
Q 117		M97320099	ケーブル (ソレノイド)	Cable (solenoid)	1	1
Q 118		M97318099	ケーブル (サーボモータデンケン)	Cable (servo motor)	1	1
Q 201		MB50A0598	デンジハントリツケイタ	Solenoid valve mounting plate	1	1
Q 202		M91067004	SW-PWブラマイナヘネジ M5X10	Screw M5X10	3	3
Q 203		MB50E0599	デンジハンケーブルクミタテ	Solenoid valve complete	1	1
Q 204		MB50A0599	デンジハン	Solenoid valve	3	3
Q 205		M91035089	サイレンサ	Muffler	2	2
Q 206		MA20A7571	ワンタッチツギテ	Quick joint	1	1
Q 207		MA20A8571	Lカタワンタッチツギテ	L-type quick joint	2	2
Q 208		M90511050	ミカキザガネ 5	Washer 5	2	2
Q 209		M95003017	セフテイソケット M5X8	Bolt M5X8	2	2
Q 210		MB61A0963	フィルタレギュレータ	Filter regulator	1	1
Q 211		M91276004	SW-PWブラマイナヘネジ M4X30	Screw M4X30	4	4

From the library of: Diamond Needle Corp

□ テーブル関係
TABLE & STAND

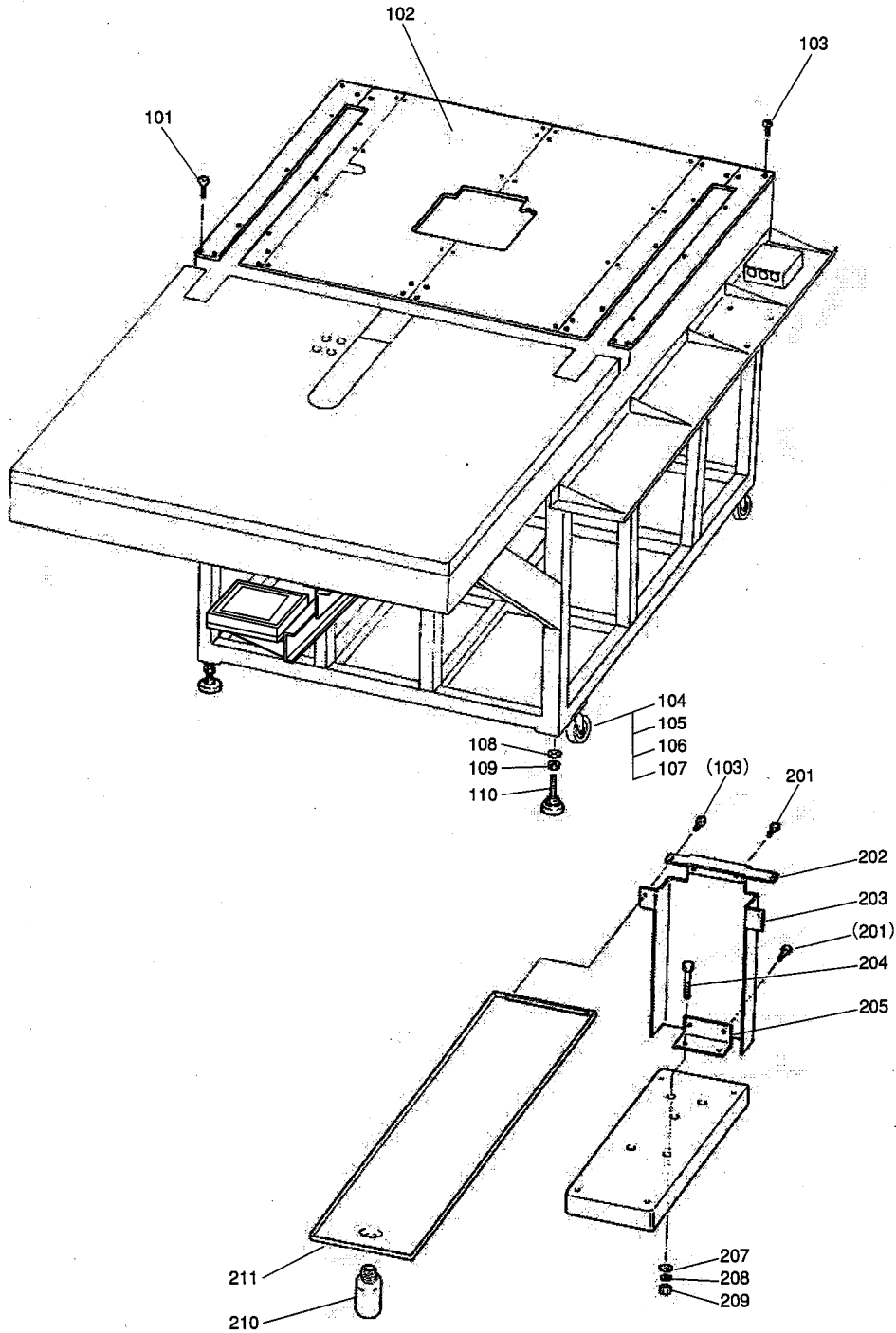

[R]テーブル関係
TABLE & STAND

Fig no.	変更 Mod.	部品コード Parts no.	品名	Description	数量	
					Amt. Req. 5050	10050
R 101		M91064004	サラネジ M4X6	Screw M4X6	36	36
R 102		ME50A0595	テーブルカバーイタ	Table cover assy	1	1
R 103		M91054004	SW-PWプライナヘネジ M4X8	Screw M4X8	52	52
R 104		MB50A1972	キャスター	Castor	4	4
R 105		M98004021	ロックアナツキボルト M8X20	Bolt M8X20	16	16
R 106		M90823050	ミガキザガネ 8	Washer 8	16	16
R 107		M90803053	ハネザガネ 8	Spring washer 8	16	16
R 108		M92002050	ミガキザガネ 20	Washer 20	4	4
R 109		M95021045	ロックナット M20	Nut M20	4	4
R 110		MA35A0166	アジャスタフット	Ajustor	4	4
R 201		M91071004	SW-MWプライナヘネジ M4X8	Screw M4X8	6	6
R 202		MB50A0420	ベルトカバーコティイタ	Cover adapter	1	1
R 203		MB50E1776	ベルトカバー	Belt cover	1	1
R 204		M95006021	ロックアナツキボルト M5X30	Bolt M5X30	2	2
R 205		MA35B7601	ベルトカバートリツケイタ	Adapter	1	1
R 206		MB50A6601	モータートリツケイタ	Motor adapter	1	1
R 207		M90511050	ミガキザガネ 5	Washer 5	2	2
R 208		M90504053	ハネザガネ 5	Spring washer 5	2	2
R 209		M91382045	ロックナット M5	Nut M5	2	2
R 210		MF20A0130	アブラビン	Oil bottle	1	1
R 211		MA60A0131	アブラウケケミタ	Oil pan	1	1

付属品
ACCESSORIES

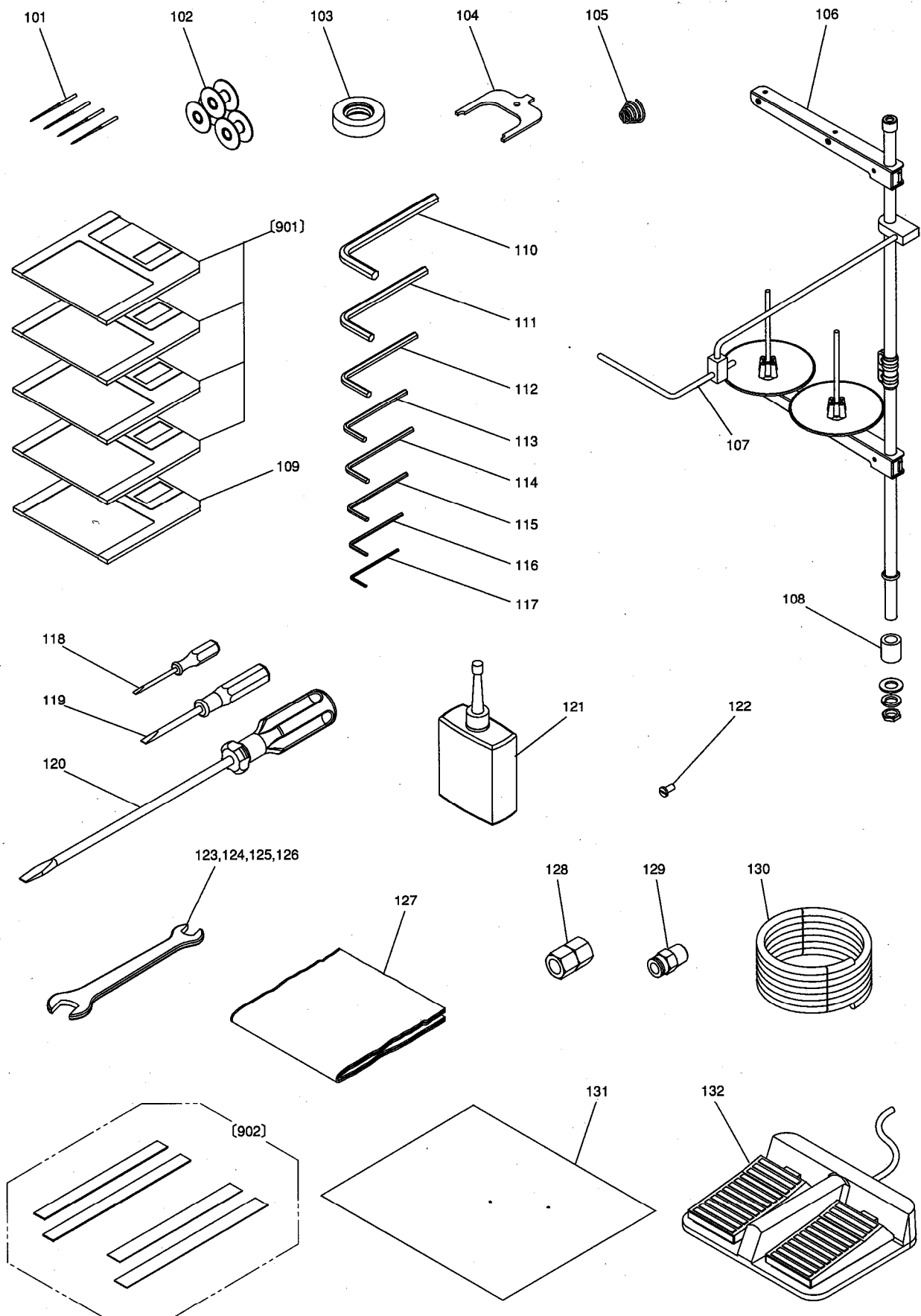

[S] 付属品
ACCESSORIES

Fig no.	変更 Mod.	部品コード Parts no.	品名	Description	数量	
					5050	10050
S 101	MS02A0128	MS02A0128	ミシンハリ DPX17#18	Needle DPX17#18	4	4
S 102	MA10A0123	MA10A0123	ホビン	Bobbin	3	3
S 103	MS03A0417	MS03A0417	ゴムワ (イトマキヨウ)	Tire (for bobbin winder)	1	1
S 104	MF01A0565	MF01A0565	カクドチョウセイグ	Speed command disk adjusting plate	1	1
S 105	MN52A1245	MN52A1245	エンスイバネ	Tension spring	1	1
S 106	MF40E0193	MF40E0193	イトタテダイクミタテ	Cotton stand assy	1	1
S 107	MA35A0180	MA35A0180	イトアンナイ	Thread guide	1	1
S 108	MA30A0352	MA30A0352	イトタテダイカラ	Cotton stand collar	1	1
S 109	MB60A1990	MB60A1990	データーフロッピーディスク	Pattern data F/D	1	1
S 110	MS05A1976	MS05A1976	ロツカクホウレンチ 6	Hexagonal wrench 6	1	1
S 111	MS05A0976	MS05A0976	ロツカクホウレンチ 5	Hexagonal wrench 5	1	1
S 112	MS01A1976	MS01A1976	ロツカクホウレンチ 4	Hexagonal wrench 4	1	1
S 113	MF90A0976	MF90A0976	ロツカクホウレンチ 1/8"	Hexagonal wrench 1/8"	1	1
S 114	MS02A2976	MS02A2976	ロツカクホウレンチ 3	Hexagonal wrench 3	1	1
S 115	MS02A1976	MS02A1976	ロツカクホウレンチ 2.5	Hexagonal wrench 2.5	1	1
S 116	MS02A0976	MS02A0976	ロツカクホウレンチ 2	Hexagonal wrench 2	1	1
S 117	MS10A0976	MS10A0976	ロツカクホウレンチ 1.5	Hexagonal wrench 1.5	1	1
S 118	MB02A1608	MB02A1608	ドライバ (ショウ)	Screw driver (small)	1	1
S 119	MB02A0608	MB02A0608	ドライバ (チュウ)	Screw driver (middle)	1	1
S 120	MF00A0608	MF00A0608	ドライバ (ダイ)	Screw driver (large)	1	1
S 121	MF10A0149	MF10A0149	アブラサシ	Oiler with oil	1	1
S 122	M90992002	M90992002	ヒラネジ M4X8	Screw M4X8	10	15
S 123	MS02A0479	MS02A0479	スパナ 13-17	Spanner 13-17	1	1
S 124	MM10A1479	MM10A1479	スパナ 10-14	Spanner 10-14	1	1
S 125	MS10A1976	MS10A1976	スパナ 8-9	Spanner 8-9	1	1
S 126	MS10A2976	MS10A2976	スパナ 6-7	Spanner 6-7	1	1
S 127	MA20A0734	MA20A0734	ビニルカバー	Polyethylene cover	1	1
S 128	M91010089	M91010089	ロツカクソケット	Socket	1	1
S 129	MA30A0571	MA30A0571	ワンタッチツキテ	Quick joint	1	1
S 130	MS06A0567	MS06A0567	エアチューブ	Air tube	1	1
S 131	MB50A0797	MB50A0797	ホコフィルム	Film sheet	1	*
S 132	MB15A0797	MB15A0797	ホコフィルム	Film sheet	*	1
S 133	M860A0FSW	M860A0FSW	フットスイッチ	Foot switch	1	1
S 901	ME20E0990	ME20E0990	システムフロッピーディスク (4マイ)	System F/D (4discs)	1	1
S 902	MB50E0691	MB50E0691	ハッキンセット	Clamp pad set	1	*
S 902	MB15E0691	MB15E0691	ハッキンセット	Clamp pad set	*	1

T オプションパーツ
 OPTION PARTS

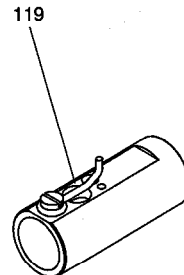
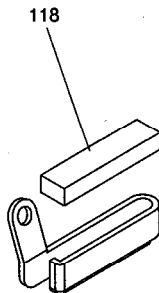
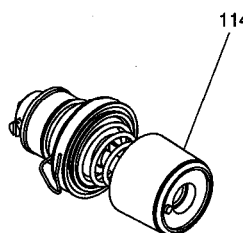
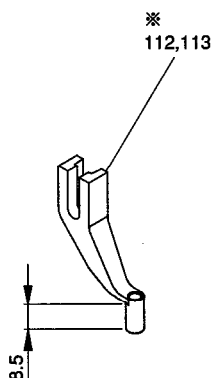
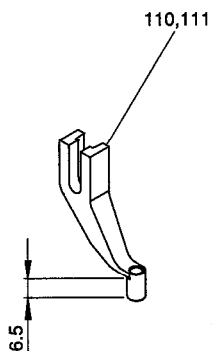
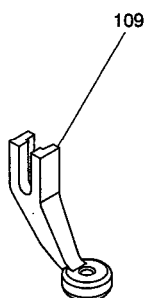
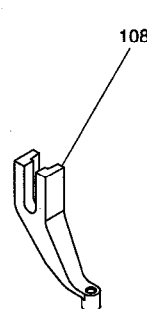
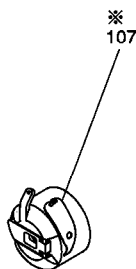
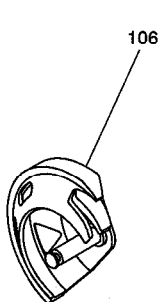
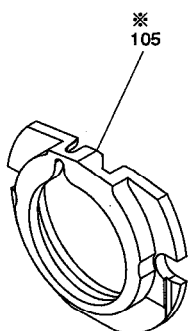
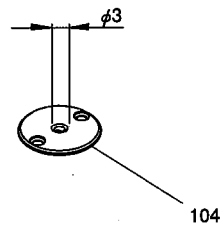
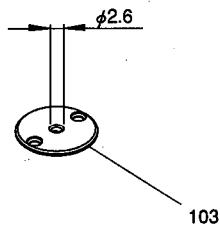
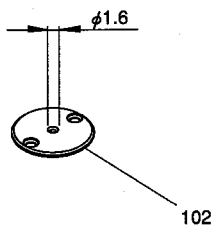

注：図中Fig.No.に※印を付した部品は電子ミシンPLK-E5050-LG、ならびにPLK-E10050-LGの機種に使用しています。
 Note : The parts marked ※ on Fig Number are used for PLK-E5050-LG and PLK-E10050-LG.

[T]オプションパーツ
OPTION PARTS

Fig no.	変更 Mod.	部品コード Parts no.	品名	Description	数量	
					Amt. Req. 5050	10050
T 101		MA35A0128	ミシンハリ PDX17#24	Needle DPX17#24	1	1
T 102		MS03A0101	ハリイタ (ウスモ/ヨウ) φ1.6	Needle plate (for light) φ1.6	1	1
T 103		MS03A2101	ハリイタ (アツモ/ヨウ) φ2.6	Needle plate (for heavy) φ2.6	1	1
T 104		MS17A0101	ハリイタ (アツモ/ヨウ) φ3	Needle plate (for heavy) φ3	1	1
T 105		MS01A1616	ナカマオサエ (アツモ/ヨウ)	Inner hook clasper (for heavy)	1	1
T 106		MS17A1120	ナカマ (アツモ/ヨウ)	Inner hook (for heavy)	1	1
T 107		MA45A0700	イタバネ	Tension plate	1	1
T 108		MV30A1256	ナカオサエ (ウスモ/ヨウ)	Presser foot (for light)	1	1
T 109		MV35A0106	サヲオサエ	Presser foot	1	1
T 110		MS03A0256	ナカオサエ φ3	Presser foot φ3	1	1
T 111		MS03A1256	ナカオサエ φ2	Presser foot φ2	1	1
T 112		MA35A0256	ナカオサエ φ3	Presser foot φ3	1	1
T 113		MA35A1256	ナカオサエ φ2	Presser foot φ2	1	1
T 114		MS04E1210	ウワイトチョウセツキ (クミ)	Thread tension regulator assy	1	1
T 115		MF10A1245	エンスイバネ (プリテンションヨウ)	Spring (for pretension)	1	1
T 116		MN10A3245	エンスイバネ (ウワイトチョウセツキヨウ)	Spring (for thread tension regulator)	1	1
T 117		MF23C0245	エンスイバネ (ウワイトチョウセツキヨウ)	Spring (for thread tension regulator)	1	1
T 118		MS03A0181	イトアンナイ	Thread guide	1	1
T 119		MS10A0180	イトアンナイ	Thread guide	1	1

索引
INDEX-1

部品コード Parts No.	ページ Page	Fig No.	部品コード Parts No.	ページ Page	Fig No.	部品コード Parts No.	ページ Page	Fig No.	部品コード Parts No.	ページ Page	Fig No.
K14M71725402	→ P29	→ Q 106	M90909003	→ P11	→ F 115	M91101017	→ P13	→ G 120	M93001050	→ P7	→ D 106
M800E1CON	→ P29	→ Q 108	M90920002	→ P5	→ C 109	M91101046	→ P5	→ C 140	M93002052	→ P21	→ L 121
M860A0FSW	→ P33	→ S 133	M90922002	→ P11	→ F 139	M91102045	→ P13	→ G 155	M93006050	→ P9	→ E 133
M90001060	→ P9	→ E 131	M90939002	→ P5	→ C 110	M91104045	→ P13	→ G 148	M93202047	→ P11	→ F 131
M90101017	→ P13	→ G 150	M90971004	→ P17	→ J 108	M91108001	→ P13	→ G 165	M93220035	→ P11	→ F 130
M90204060	→ P5	→ C 142	↑	→ P21	→ L 135	M91109045	→ P13	→ G 160	M94001017	→ P21	→ L 161
M90307053	→ P25	→ N 109	M90990002	→ P7	→ D 138	M91110002	→ P3	→ B 117	↑	→ P23	→ M 113
M90317050	→ P25	→ N 108	↑	→ P13	→ G 101	M91112002	→ P15	→ H 109	M94001021	→ P13	→ G 122
M90325065	→ P11	→ F 128	M90992002	→ P3	→ B 125	M91119002	→ P7	→ D 145	M94002067	→ P13	→ G 133
M90330065	→ P7	→ D 105	↑	→ P33	→ S 122	M91127015	→ P15	→ H 101	M94003021	→ P17	→ J 101
M90406064	→ P7	→ D 143	M91004067	→ P5	→ C 119	M91129015	→ P13	→ G 111	M94003047	→ P17	→ J 111
M90421050	→ P7	→ D 102	M91005067	→ P5	→ C 121	M91131002	→ P11	→ F 146	M94006017	→ P21	→ L 164
↑	→ P13	→ G 123	M91007045	→ P13	→ G 137	M91182080	→ P3	→ B 119	↑	→ P23	→ M 121
↑	→ P15	→ H 108	↑	→ P15	→ H 106	M91203002	→ P9	→ E 101	M94007017	→ P17	→ J 144
M90423060	→ P11	→ F 145	M91010089	→ P33	→ S 128	M91214015	→ P13	→ G 117	↑	→ P21	→ L 167
M90424053	→ P13	→ G 138	M91011004	→ P5	→ C 135	M91219015	→ P11	→ F 147	↑	→ P23	→ M 111
↑	→ P15	→ H 107	M91013004	→ P5	→ C 104	M91221001	→ P7	→ D 126	M94008017	→ P23	→ M 120
M90439037	→ P29	→ Q 107	M91035089	→ P29	→ Q 205	↑	→ P9	→ E 110	M95001017	→ P17	→ J 135
M90447037	→ P3	→ B 112	M91050020	→ P13	→ G 128	M91223001	→ P7	→ D 123	↑	→ P21	→ L 120
M90500085	→ P9	→ E 116	M91053020	→ P5	→ C 133	↑	→ P9	→ E 104	↑	→ P23	→ M 128
M90504053	→ P13	→ G 163	↑	→ P7	→ D 120	M91224001	→ P13	→ G 116	M95001021	→ P9	→ E 126
↑	→ P31	→ R 208	M91054004	→ P3	→ B 102	M91276004	→ P5	→ C 102	M95001047	→ P17	→ J 107
M90504065	→ P21	→ L 154	↑	→ P5	→ C 131	↑	→ P29	→ Q 211	↑	→ P19	→ K 120
M90510065	→ P17	→ J 136	↑	→ P15	→ H 116	M91300004	→ P3	→ B 108	M95002017	→ P17	→ J 106
↑	→ P21	→ L 172	↑	→ P21	→ L 134	M91305010	→ P17	→ J 148	↑	→ P19	→ K 118
M90511050	→ P13	→ G 162	↑	→ P25	→ N 101	M91330004	→ P23	→ M 103	↑	→ P23	→ M 114
↑	→ P19	→ K 115	↑	→ P27	→ P 104	M91382045	→ P13	→ G 121	M95003017	→ P11	→ F 150
↑	→ P21	→ L 140	↑	→ P31	→ R 103	↑	→ P15	→ H 112	↑	→ P21	→ L 136
↑	→ P29	→ Q 208	M91055020	→ P5	→ C 112	↑	→ P31	→ R 209	↑	→ P23	→ M 131
↑	→ P31	→ R 207	M91056004	→ P11	→ F 104	M91383045	→ P13	→ G 131	↑	→ P29	→ Q 209
M90512050	→ P17	→ J 143	↑	→ P13	→ G 139	M91503001	→ P9	→ E 112	M95003021	→ P13	→ G 144
M90513065	→ P13	→ G 113	↑	→ P25	→ N 102	M91506001	→ P11	→ F 136	M95004017	→ P17	→ J 103
M90601064	→ P5	→ C 123	↑	→ P29	→ Q 109	M91515022	→ P11	→ F 144	↑	→ P19	→ K 117
M90604065	→ P21	→ L 157	M91056020	→ P23	→ M 129	M91520002	→ P7	→ D 112	↑	→ P21	→ L 131
M90605010	→ P13	→ G 103	M91057020	→ P5	→ C 115	M91551015	→ P11	→ F 125	↑	→ P23	→ M 116
M90624053	→ P21	→ L 116	↑	→ P25	→ N 118	M91572045	→ P11	→ F 122	M95004020	→ P5	→ C 152
M90631050	→ P11	→ F 123	M91058004	→ P17	→ J 123	M91576045	→ P13	→ G 142	↑	→ P11	→ F 157
↑	→ P21	→ L 113	↑	→ P19	→ K 110	↑	→ P19	→ K 127	M95004021	→ P9	→ E 107
M90632050	→ P11	→ F 133	M91058020	→ P11	→ F 113	↑	→ P21	→ L 117	↑	→ P13	→ G 149
M90802002	→ P15	→ H 102	M91059004	→ P7	→ D 103	M91602001	→ P7	→ D 118	M95004023	→ P13	→ G 125
M90802003	→ P9	→ E 132	↑	→ P17	→ J 112	M91602046	→ P5	→ C 124	M95005017	→ P15	→ H 110
↑	→ P25	→ N 113	M91064004	→ P3	→ B 128	M91603003	→ P11	→ F 121	M95006017	→ P11	→ F 153
M90803053	→ P31	→ R 107	↑	→ P17	→ J 131	M91606001	→ P7	→ D 135	M95006020	→ P7	→ D 139
M90806002	→ P3	→ B 114	↑	→ P19	→ K 131	↑	→ P11	→ F 129	M95006021	→ P21	→ L 119
M90815002	→ P7	→ D 132	↑	→ P21	→ L 159	M91610046	→ P5	→ C 150	↑	→ P31	→ R 204
M90823050	→ P31	→ R 106	↑	→ P31	→ R 101	M91650020	→ P9	→ E 114	M95008017	→ P19	→ K 114
M90830004	→ P19	→ K 122	M91067004	→ P29	→ Q 202	M91652020	→ P13	→ G 143	↑	→ P21	→ L 141
M90853002	→ P9	→ E 129	M91071004	→ P17	→ J 129	M91688015	→ P11	→ F 109	M95011021	→ P17	→ J 133
M90859004	→ P3	→ B 124	↑	→ P19	→ K 102	M91689015	→ P11	→ F 107	↑	→ P21	→ L 176
M90875045	→ P25	→ N 110	↑	→ P29	→ Q 101	M91801035	→ P11	→ F 101	M95015021	→ P13	→ G 164
M90883080	→ P3	→ B 106	↑	→ P31	→ R 201	M91802006	→ P7	→ D 134	M95021045	→ P31	→ R 109
M90901002	→ P5	→ C 143	M91073004	→ P17	→ J 124	M91802045	→ P9	→ E 105	M95049021	→ P13	→ G 136
M90906003	→ P3	→ B 123	↑	→ P29	→ Q 103	↑	→ P11	→ F 102	M95053095	→ P19	→ K 116
↑	→ P13	→ G 108	M91079004	→ P3	→ B 116	M91910080	→ P3	→ B 103	M95054095	→ P21	→ L 115
M90909003	→ P3	→ B 120	M91082004	→ P13	→ G 152	M92002050	→ P31	→ R 108	M96001001	→ P19	→ K 104

索引
INDEX-2

部品コード Parts No.	ページ Page	Fig No.	部品コード Parts No.	ページ Page	Fig No.	部品コード Parts No.	ページ Page	Fig No.	部品コード Parts No.	ページ Page	Fig No.
M96001001	→ P21	→ L 105	MA35A0572	→ P13	→ G 154	MB50A0456	→ P21	→ L 104	MB50A3339	→ P29	→ Q 102
M96002001	→ P19	→ K 124	MA35A0708	→ P13	→ G 130	MB50A0476	→ P17	→ J 145	MB50A3390	→ P21	→ L 109
↑	→ P21	→ L 110	MA35A0833	→ P7	→ D 121	MB50A0477	→ P23	→ M 124	MB50A3426	→ P23	→ M 130
M96004052	→ P13	→ G 110	MA35A1256	→ P35	→ T 113	MB50A0523	→ P17	→ J 140	MB50A3523	→ P21	→ L 171
M96005017	→ P21	→ L 107	MA35A1572	→ P13	→ G 132	MB50A0557	→ P23	→ M 105	MB50A3601	→ P23	→ M 106
M96006017	→ P21	→ L 114	MA35A1833	→ P9	→ E 117	MB50A0571	→ P17	→ J 117	MB50A3758	→ P21	→ L 112
M96006052	→ P17	→ J 119	MA35A1950	→ P13	→ G 126	MB50A0595	→ P23	→ M 117	MB50A3920	→ P21	→ L 169
M96007052	→ P21	→ L 163	MA35A2530	→ P13	→ G 129	MB50A0598	→ P29	→ Q 201	MB50A4390	→ P21	→ L 111
M96008052	→ P23	→ M 112	MA35A2572	→ P7	→ D 141	MB50A0599	→ P29	→ Q 204	MB50A4601	→ P23	→ M 115
M96009052	→ P23	→ M 118	MA35B7601	→ P31	→ R 205	MB50A0603	→ P19	→ K 119	MB50A4758	→ P21	→ L 158
M96015021	→ P21	→ L 122	MA35E0450	→ P9	→ E 120	MB50A0620	→ P21	→ L 133	MB50A5601	→ P23	→ M 119
M96029021	→ P19	→ K 126	MA45A0700	→ P35	→ T 107	MB50A0743	→ P17	→ J 104	MB50A5758	→ P21	→ L 108
M96062021	→ P13	→ G 158	MA60A0131	→ P31	→ R 211	MB50A0751	→ P19	→ K 128	MB50A6601	→ P31	→ R 206
M97318099	→ P29	→ Q 118	MA70A2758	→ P21	→ L 165	MB50A0758	→ P17	→ J 130	MB50A6758	→ P21	→ L 177
M97319099	→ P29	→ Q 116	MB01A0436	→ P25	→ N 114	MB50A0767	→ P17	→ J 138	MB50B0339	→ P17	→ J 126
M97320099	→ P29	→ Q 117	MB02A0608	→ P33	→ S 119	↑	→ P21	→ L 173	MB50E0470	→ P3	→ B 126
M97321099	→ P29	→ Q 114	MB02A1608	→ P33	→ S 118	MB50A0778	→ P17	→ J 141	MB50E0599	→ P29	→ Q 203
M98003015	→ P9	→ E 108	MB15A0105	→ P23	→ M 102	↑	→ P21	→ L 170	MB50E0691	→ P33	→ S 902
M98003017	→ P17	→ J 121	MB15A0272	→ P23	→ M 101	MB50A0780	→ P23	→ M 107	MB50E0776	→ P19	→ K 109
M98004017	→ P17	→ J 127	MB15A0308	→ P23	→ M 109	MB50A0797	→ P3	→ B 127	MB50E1776	→ P31	→ R 203
M98004021	→ P31	→ R 105	MB15A0339	→ P17	→ J 122	↑	→ P33	→ S 131	MB50E3743	→ P17	→ J 901
M98018022	→ P17	→ J 118	MB15A0413	→ P17	→ J 115	MB50A0799	→ P23	→ M 104	MB60A0366	→ P29	→ Q 104
M98605047	→ P17	→ J 120	MB15A0523	→ P17	→ J 140	MB50A0849	→ P19	→ K 125	MB60A0601	→ P3	→ B 118
M99006063	→ P5	→ C 114	MB15A0797	→ P3	→ B 127	MB50A0922	→ P21	→ L 152	MB60A0694	→ P7	→ D 111
↑	→ P11	→ F 114	↑	→ P33	→ S 132	MB50A0971	→ P21	→ L 153	MB60A0740	→ P9	→ E 102
MA04A1530	→ P5	→ C 108	MB15A2920	→ P17	→ J 102	MB50A0972	→ P21	→ L 155	MB60A0915	→ P25	→ N 105
MA10A0120	→ P9	→ E 124	MB15B0339	→ P17	→ J 126	MB50A1165	→ P21	→ L 123	MB60A1601	→ P5	→ C 118
MA10A0123	→ P9	→ E 122	MB15E0470	→ P3	→ B 126	MB50A1226	→ P21	→ L 162	MB60A1620	→ P3	→ B 105
↑	→ P33	→ S 102	MB15E0691	→ P33	→ S 902	MB50A1339	→ P17	→ J 132	MB60A1780	→ P27	→ P 122
MA10B2476	→ P13	→ G 106	MB35A0230	→ P7	→ D 122	MB50A1390	→ P19	→ K 123	MB60A1990	→ P33	→ S 109
MA16E0210	→ P5	→ C 904	MB35A0600	→ P5	→ C 101	MB50A1407	→ P21	→ L 138	MB60A2352	→ P29	→ Q 105
MA20A0194	→ P5	→ C 116	MB35A0708	→ P13	→ G 153	MB50A1413	→ P17	→ J 116	MB60A2406	→ P7	→ D 101
MA20A0392	→ P13	→ G 118	MB35E0776	→ P3	→ B 109	MB50A1426	→ P23	→ M 110	MB60A5601	→ P29	→ Q 111
MA20A0476	→ P5	→ C 105	MB35E0975	→ P13	→ G 134	MB50A1454	→ P23	→ M 125	MB60A5780	→ P29	→ Q 112
MA20A0584	→ P5	→ C 132	MB50A0105	→ P23	→ M 102	MB50A1476	→ P21	→ L 139	MB60A6780	→ P29	→ Q 113
MA20A0603	→ P15	→ H 111	MB50A0161	→ P19	→ K 132	MB50A1523	→ P19	→ K 107	MB60E0234	→ P7	→ D 904
MA20A0650	→ P23	→ M 123	MB50A0165	→ P21	→ L 103	MB50A1601	→ P17	→ J 146	MB60E0682	→ P7	→ D 113
MA20A0734	→ P33	→ S 127	MB50A0196	→ P17	→ J 128	MB50A1743	→ P17	→ J 105	MB60E1682	→ P7	→ D 901
MA20A0740	→ P9	→ E 119	MB50A0226	→ P19	→ K 111	MB50A1751	→ P21	→ L 175	MB60E1956	→ P9	→ E 901
MA20A0980	→ P25	→ N 119	MB50A0272	→ P23	→ M 101	MB50A1758	→ P19	→ K 101	MB60E2750	→ P5	→ C 113
MA20A1780	→ P27	→ P 112	MB50A0308	→ P23	→ M 109	MB50A1767	→ P19	→ K 106	MB60E3339	→ P25	→ N 902
MA20A1910	→ P13	→ G 114	MB50A0339	→ P17	→ J 122	↑	→ P21	→ L 106	MB60E6339	→ P3	→ B 122
MA20A4454	→ P13	→ G 127	MB50A0352	→ P19	→ K 129	MB50A1922	→ P21	→ L 168	MB61A0963	→ P29	→ Q 210
MA20A6688	→ P27	→ P 117	↑	→ P23	→ M 126	MB50A1957	→ P21	→ L 151	MB62A0352	→ P5	→ C 103
MA20A7571	→ P29	→ Q 206	MB50A0370	→ P19	→ K 121	MB50A1972	→ P31	→ R 104	MB62A0453	→ P9	→ E 113
MA20A8571	→ P29	→ Q 207	MB50A0390	→ P19	→ K 105	MB50A2339	→ P19	→ K 130	MB62A0454	→ P13	→ G 115
MA30A0352	→ P33	→ S 108	MB50A0407	→ P17	→ J 147	MB50A2390	→ P21	→ L 101	MB62A0626	→ P11	→ F 140
MA30A0364	→ P21	→ L 102	MB50A0413	→ P17	→ J 115	MB50A2426	→ P23	→ M 127	MB62A0777	→ P3	→ B 107
MA30A0571	→ P33	→ S 129	MB50A0419	→ P17	→ J 113	MB50A2454	→ P21	→ L 156	MB65A0601	→ P29	→ Q 110
MA30A0751	→ P17	→ J 134	MB50A0420	→ P31	→ R 202	MB50A2523	→ P21	→ L 125	ME03A0270	→ P25	→ N 106
↑	→ P21	→ L 118	MB50A0421	→ P21	→ L 160	MB50A2743	→ P17	→ J 114	ME10A0148	→ P9	→ E 118
MA35A0128	→ P35	→ T 101	MB50A0426	→ P17	→ J 125	MB50A2758	→ P19	→ K 112	ME10A0261	→ P11	→ F 103
MA35A0166	→ P31	→ R 110	MB50A0454	→ P19	→ K 113	MB50A2767	→ P19	→ K 108	ME10A0572	→ P11	→ F 105
MA35A0180	→ P33	→ S 107	MB50A0456	→ P17	→ J 137	↑	→ P21	→ L 124	ME10A0742	→ P3	→ B 101
MA35A0256	→ P35	→ T 112	↑	→ P19	→ K 103	MB50A2920	→ P17	→ J 102	ME10A0763	→ P11	→ F 111

索引
INDEX-3

部品コード Parts No.	ページ Page	Fig No.	部品コード Parts No.	ページ Page	Fig No.	部品コード Parts No.	ページ Page	Fig No.	部品コード Parts No.	ページ Page	Fig No.
ME10A0956	--- P11	--- F 124	MF01A0181	--- P7	--- D 133	MN60A0620	--- P3	--- B 104	MS03A0703	--- P11	--- F 132
ME10A1252	--- P11	--- F 142	MF01A0259	--- P7	--- D 107	↑	--- P27	--- P 133	MS03A1101	--- P13	--- G 104
ME10A1780	--- P27	--- P 103	MF01A0476	--- P7	--- D 110	MN60A0750	--- P15	--- H 113	MS03A1256	--- P35	--- T 111
ME10A1956	--- P11	--- F 118	MF01A0565	--- P33	--- S 104	MN70A1780	--- P11	--- F 116	MS03A1530	--- P25	--- N 117
ME10A6910	--- P11	--- F 110	MF01A1476	--- P7	--- D 108	MN72A0975	--- P13	--- G 124	MS03A1572	--- P11	--- F 134
ME10A7910	--- P11	--- F 112	MF10A0149	--- P33	--- S 121	MN72A1694	--- P7	--- D 109	MS03A2101	--- P35	--- T 103
ME10E0452	--- P9	--- E 902	MF10A0181	--- P5	--- C 151	MS01A0121	--- P9	--- E 128	MS03A2780	--- P27	--- P 105
ME10E1830	--- P3	--- B 113	MF10A0187	--- P5	--- C 146	MS01A0160	--- P3	--- B 110	MS03A6154	--- P11	--- F 106
ME10E3601	--- P25	--- N 104	MF10A0267	--- P11	--- F 137	MS01A0192	--- P13	--- G 112	MS03B0838	--- P13	--- G 109
ME20E0990	--- P33	--- S 901	MF10A0325	--- P7	--- D 137	MS01A0329	--- P9	--- E 130	MS03E0662	--- P7	--- D 136
ME25A0434	--- P11	--- F 155	MF10A0553	--- P5	--- C 145	MS01A0348	--- P13	--- G 145	MS04E1210	--- P35	--- T 114
ME25A0454	--- P7	--- D 142	MF10A0555	--- P5	--- C 127	MS01A0350	--- P7	--- D 125	MS05A0454	--- P17	--- J 139
ME25A0477	--- P11	--- F 149	MF10A0709	--- P5	--- C 144	MS01A0361	--- P3	--- B 121	↑	--- P21	--- L 174
ME25A0530	--- P5	--- C 111	MF10A1245	--- P35	--- T 115	MS01A0383	--- P7	--- D 905	MS05A0456	--- P21	--- L 166
ME25A0551	--- P5	--- C 106	MF10A1555	--- P5	--- C 138	MS01A0477	--- P3	--- B 111	MS05A0976	--- P33	--- S 111
ME25A0571	--- P11	--- F 152	MF10A2740	--- P27	--- P 102	MS01A0508	--- P9	--- E 106	MS05A1976	--- P33	--- S 110
ME25A0601	--- P11	--- F 151	MF20A0130	--- P31	--- R 210	MS01A0572	--- P9	--- E 134	MS06A0567	--- P33	--- S 130
ME25A0682	--- P7	--- D 144	MF21D0181	--- P7	--- D 130	MS01A0611	--- P9	--- E 125	MS07A0228	--- P15	--- H 105
ME25A0833	--- P7	--- D 140	MF23C0245	--- P35	--- T 117	MS01A0660	--- P7	--- D 128	MS08A0454	--- P13	--- G 157
ME25A0950	--- P5	--- C 107	MF36A0245	--- P5	--- C 139	MS01A0663	--- P7	--- D 127	MS08A0616	--- P9	--- E 123
ME25A1454	--- P11	--- F 156	MF36A0750	--- P15	--- H 103	MS01A0761	--- P9	--- E 115	MS08A0740	--- P27	--- P 109
ME25E0190	--- P5	--- C 901	MF36A1180	--- P5	--- C 134	MS01A0833	--- P9	--- E 103	MS09A0950	--- P9	--- E 127
ME25E0331	--- P7	--- D 906	MF40E0193	--- P33	--- S 106	MS01A0891	--- P9	--- E 109	MS10A0180	--- P35	--- T 119
ME40A0571	--- P11	--- F 154	MF60A0700	--- P11	--- F 126	MS01A1392	--- P13	--- G 161	MS10A0232	--- P7	--- D 903
ME40A0738	--- P11	--- F 148	MF60A0742	--- P27	--- P 101	MS01A1476	--- P13	--- G 105	MS10A0780	--- P27	--- P 114
ME40E0688	--- P27	--- P 132	MF60A2740	--- P7	--- D 124	MS01A1572	--- P13	--- G 146	MS10A0976	--- P33	--- S 117
ME40E0746	--- P15	--- H 115	MF60A5740	--- P27	--- P 124	MS01A1616	--- P35	--- T 105	MS10A0982	--- P25	--- N 116
ME40E1688	--- P27	--- P 130	MF70A0350	--- P11	--- F 143	MS01A1739	--- P3	--- B 115	MS10A1740	--- P7	--- D 115
ME40E2688	--- P27	--- P 131	MF70A0352	--- P7	--- D 117	MS01A1740	--- P27	--- P 106	MS10A1976	--- P33	--- S 125
ME40E3688	--- P27	--- P 123	MF70A1180	--- P5	--- C 153	MS01A1976	--- P33	--- S 112	MS10A2976	--- P33	--- S 126
ME40E4688	--- P27	--- P 119	MF80A0780	--- P27	--- P 107	MS01A2392	--- P13	--- G 159	MS14A0350	--- P5	--- C 120
ME40E5688	--- P27	--- P 128	MF90A0361	--- P15	--- H 104	MS01A3352	--- P13	--- G 901	MS14A0553	--- P5	--- C 128
ME40E6688	--- P27	--- P 116	MF90A0553	--- P5	--- C 137	MS01A8796	--- P27	--- P 129	MS14A0572	--- P5	--- C 122
ME40E7688	--- P27	--- P 111	MF90A0976	--- P33	--- S 113	MS01A9796	--- P27	--- P 126	MS14A0682	--- P7	--- D 119
ME40E8688	--- P27	--- P 121	MG30A0664	--- P7	--- D 129	MS01E0351	--- P13	--- G 147	MS14A0740	--- P27	--- P 125
ME40E9688	--- P27	--- P 110	MG30A0740	--- P11	--- F 117	MS01E0430	--- P13	--- G 135	MS14A0838	--- P13	--- G 107
ME40F0688	--- P27	--- P 120	MG30A0760	--- P11	--- F 901	MS01E0580	--- P7	--- D 902	MS14A1180	--- P5	--- C 129
ME40F1688	--- P27	--- P 115	MG30A0833	--- P11	--- F 120	MS01E0975	--- P13	--- G 151	MS14A1620	--- P27	--- P 113
ME50A0273	--- P23	--- M 122	MG30B0226	--- P11	--- F 108	MS02A0128	--- P7	--- D 131	MS14A3601	--- P13	--- G 140
ME50A0484	--- P17	--- J 109	MG30B0740	--- P11	--- F 127	↑	--- P33	--- S 101	MS14A3603	--- P13	--- G 156
ME50A0508	--- P25	--- N 103	MG43A0181	--- P5	--- C 141	MS02A0463	--- P11	--- F 902	MS14A3780	--- P27	--- P 127
ME50A0595	--- P31	--- R 102	MG50A0740	--- P7	--- D 114	MS02A0479	--- P33	--- S 123	MS14E0180	--- P5	--- C 902
ME50A0601	--- P17	--- J 110	MG75A0265	--- P11	--- F 135	MS02A0976	--- P33	--- S 116	MS17A0101	--- P35	--- T 104
ME50A0957	--- P17	--- J 142	MG75A1476	--- P5	--- C 130	MS02A1477	--- P25	--- N 115	MS17A0125	--- P9	--- E 121
ME50A1484	--- P21	--- L 137	MM10A1479	--- P33	--- S 124	MS02A1976	--- P33	--- S 115	MS17A1120	--- P35	--- T 106
ME50A1508	--- P29	--- Q 115	MM11A0245	--- P5	--- C 126	MS02A2976	--- P33	--- S 114	MS18A0470	--- P13	--- G 102
ME50A1601	--- P21	--- L 132	MM11A0352	--- P9	--- E 111	MS02A4729	--- P25	--- N 111	MS45A0497	--- P23	--- M 108
ME50E0270	--- P25	--- N 901	MM11A0556	--- P5	--- C 147	MS02E0460	--- P11	--- F 119	MT60A0802	--- P5	--- C 149
ME50E0519	--- P13	--- G 141	MM11A0702	--- P5	--- C 125	MS02E0983	--- P25	--- N 112	MV30A0256	--- P11	--- F 141
ME50E1519	--- P15	--- H 114	MN10A0135	--- P27	--- P 118	MS03A0101	--- P35	--- T 102	MV30A1256	--- P35	--- T 108
ME50E2519	--- P25	--- N 107	MN10A1456	--- P7	--- D 104	MS03A0181	--- P35	--- T 118	MV35A0106	--- P35	--- T 109
MF00A0181	--- P5	--- C 136	MN10A3245	--- P35	--- T 116	MS03A0256	--- P35	--- T 110	MV88A0740	--- P7	--- D 116
MF00A0608	--- P33	--- S 120	MN52A1245	--- P5	--- C 148	MS03A0262	--- P11	--- F 138			
MF00A2780	--- P27	--- P 108	↑	--- P33	--- S 105	MS03A0417	--- P5	--- C 117			
MF00E0550	--- P5	--- C 903	MN55A0975	--- P13	--- G 119	↑	--- P33	--- S 103			

MEMO

Lined area for writing the memo content.

MEMO

Lined area for writing the memo content.

 **三菱電機株式会社** 〒100-8310 東京都千代田区丸の内 2-2-3(三菱電機ビル)

お問い合わせは下記へどうぞ

F A システム事業本部 機器計画部 駆動機器グループ 〒104-6212 東京都中央区晴海 1-8-12 オフィスタワー Z 14 階
代表電話番号 (03)6221-6160 代表 F A X 番号 (03)6221-6168

 **MITSUBISHI ELECTRIC CORPORATION**
FACTORY AUTOMATION SYSTEM

OFFICE TOWER Z 14F 8-12 1chome, Harumi CHUO-KU, TOKYO 104-6212, JAPAN

Phone : +81-3-6221-6060 Fax : +81-3-6221-6076